

JK-T1900B

零件样本

PARTS BOOK

**New JACK Sewing
Machine**

2013 年 4 月版

Revised edition in April, 2013

CONTENTS

目录

1、FRAME&MISCELLANEOUS COMVER COMPONENTS	1
机身及罩壳部件	
2、MAIM SHAFI & NEEDLE BAR COMPONENTS.....	3
上轴针杆部件	
3、PRESSER LIFTER & WIPER COMPONENTS	5
抬压及拨线部件	
4、SHUTTLE DRIVER SHAFT COMPONENTS	7
下轴部件	
5、THREAD TENSION COMPONENTS5	9
紧线部件	
6、THREAD TRIMMER MECHANISM COMPONENTS5	11
剪线部件	
7、FEED MECHANISM COMPONENTS5	13
送料部件	
8、PRESSER MECHANISM COMPONENTS	15
中压脚部件（1904B和1906B专用部件1）	
9、SENSOR COMPONENTS.....	17
安全开关部件	
10、THREAD STAND COMPONENTS	18
线架部件	
11、TABLE STAND COMPONENTS.....	19
台板机架部件	
12、CONTROL BOX COMPONENTS.....	21
控制箱部件	
13、OPERATION PANEL COMPONENTS.....	23
操作面板部件	
14、WIRING DIAGRAM.....	25
接线图部件	
15、ACCESSORIE PART COMPONENTS.....	26
附件部件	
20、EXCLUSIVE PARTS FOR 1903B (1)	28
1903B专用部件1	
21、EXCLUSIVE PARTS FOR 1903B (2)	30
1903B专用部件2	
22、ACCESSORIE PARTS FOR 1903B SUBBCLASSES	32
1903B附件	
23、EXCLUSIVE PARTS FOR 1904B AND 1906B	34
1904B和1906B专用部件2	

1. FRAME & MISCELLANEOUS COVER COMPONENTS

机身及罩壳部件

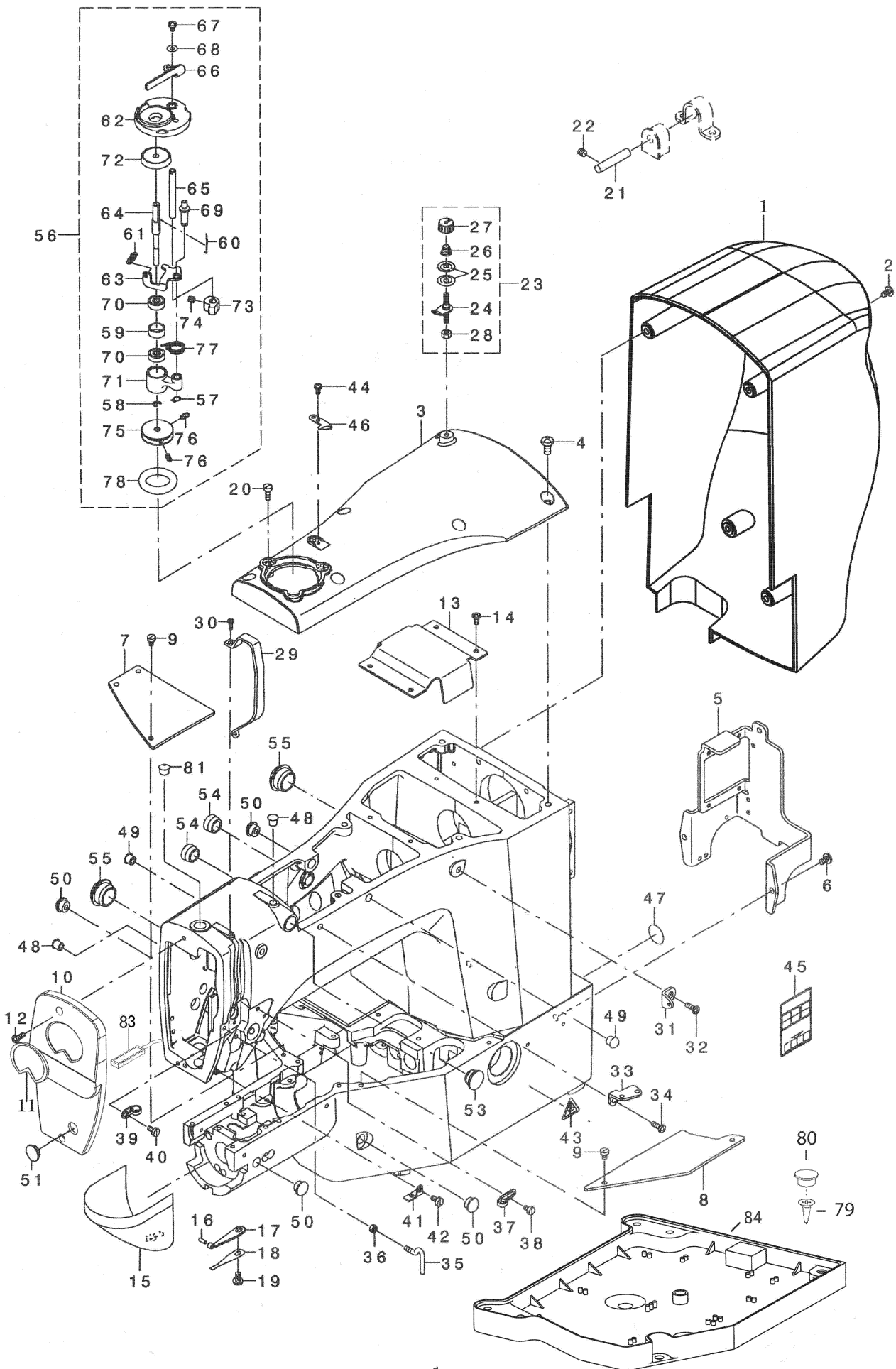

序号	注解	公司件号	DESCRIPTION	名称	用量	同类编号
1		40311022	MOTOR COVER	后罩	1	400-06475
2		403S11013	SCREW	螺钉	4	SM-5040855-SN
3		40301027	UPSIDE CVER	顶盖	1	400-06478
4		403S11009	SCREW M6 L=12	顶盖螺钉	6	SM-4061255-SP
5		40312059	PROTECTION -PLATE	电子安装板	1	400-10404
6		403S11010	SCREW	螺钉	3	SM-4050855-SP
7		301214	BED COVER LEFT	底座左盖板	1	400-06478
8		301215	BED COVER RIGHT	底座右盖板	1	400-06488
9		403S11011	SCREW M4 L=6	盖板螺钉	5	SM-6040650-TP
10		40301028	FACE COVER	面板	1	400-06481
11		30337001	FACE PLATE	商标	1	229-02506
12		403S11012	SCREW	螺钉	2	SM-4041055-SP
13		40312062	CRANK-ROD-COVER	挡油板	1	400-10405
14		403S11013	SCREW	螺钉	4	SM-5040855-SN
15		301217	CYLINDER ARM CAP	梭床罩组件	1	138-16855
16		40326035	HOOK COVER PRESSER SPRING PIN	梭床罩销	1	135-08700
17		40312138	HOOK COVER PRESSER SPRING A	梭床罩固定板	1	135-08809
18		40127014	HOOK COVER PRESSER SPRING B	梭床罩弹簧板	1	135-08908
19		403S11013	SCREW	螺钉	1	SM-5040855-SN
20		403S11015	SCREW M4 L=11	绕线器安装螺钉	3	SM-6041150-TP
21		40326001	HINGE STUD	支承销	2	B2707-761-000
22		403S11016	SCREW M6 L=6	支承销固定螺钉	4	SM-8060612-TP
23		4031301400	BOBBIN THREAD TENSION ASM	绕线夹线器组件	1	141-13468
24		1143100300	BOBBIN THREAD TENSION ROD ASM	过线销	(1)	141-13450
25		11413003	THREAD TENSION DISK	夹线片	(2)	B3126-012-000
26		11427006	CONNECTING ROD SPRING	夹线簧	(1)	D7133-555-B00
27		11411004	THREAD TENSION NUT	夹线螺母	(1)	110-72402
28		114S16001	NUT 11/64-40	固定螺母	(1)	NS-6110310-SP
29		40112002	BALANCE COVER	防护罩	1	138-16608
30		403S11017	SCREW M3 L=8	防护罩螺钉	2	SM-4030855-SN
31		40313003	THREAD GUIDE NO. 1	过线板	1	400-10414
32		403S11009	SCREW M6 L=12	过线板螺钉	1	SM-4061255-SP
33		40113004	THREAD GUIDE PLATE	双眼过线板	1	B1111-232-000
34		403S11009	SCREW M6 L=12	过线板螺钉	1	SM-4061255-SP
35		40313004	L-SHAPED-THREAD-GUIDE-A	过线钩	1	400-10571
36		403S16004	NUT M4	过线钩螺母	1	NM-6040000-SN
37		40213010	ARM THERAD GUIDE A	右线钩	1	299-20508
38		403S11011	SCREW M4 L=6	右线钩螺钉	1	SM-6040650-TP
39		40313006	TAKE-UP THERAD GUIDE B	左线钩	1	137-05108
40		403S11019	SCREW M4 L=8	左线钩螺钉	1	SM-6040860-TP
41		40313007	FRAME THERAD GUIDE (B)	下过线板	1	B1129-210-000
42		403S11019	SCREW M4 L=8	下过线板螺钉	1	SM-6040860-TP
43		- - - - -	CAUTION LABEL (25)	警告标志	1	CM-3002000-02
44		403S11020	SCREW M3X6	螺钉	1	SM-4030601-SN
45		- - - - -	SAFETY LAEBL-S	警告标志	1	CM-3002001-B1
46		11419001	THREAD CUTTER	切线刀	1	105-02300
47		- - - - -	GROUND MARK	接地标志	1	100-04109
48		40122006	RUBBER PLUG	硅油过线器油塞	2	TA-0750704-R0
49		40322019	RUBBER PLUG	油塞	2	TA-0850604-R0
50		40122016	RUBBER PLUG	油塞	8	TA-1050504-R0
51		40122017	RUBBER PLUG D=12.4 L=4	面板塞	1	TA-1250406-R0
52		- - - - -	- - - - -	- - - - -	- - - - -	- - - - -
53		40122007	RUBBER PLUG	油塞	1	TA-1470704-R0
54		40322021	PLUG	油塞	2	TA-1550902-R0
55		40122015	RUBBER PLUG	油塞	3	TA-2100904-R0
56		4033100800	BOBBIN WINDER UNIT	绕线器组件	1	262-60000
57		40329005	RETAINING RING	卡簧	(1)	RC-0560711-KP
58		40329006	E-RING 4	卡簧	(1)	RE-0400000-K0
59		40308012	BTW BEARING SPACER	挡圈	(1)	262-60802
60		40327021	BOBBIN SPRING	梭芯弹簧	(1)	262-61602
61		40327022	BTW SPRING	弹簧	(1)	262-61701
62		40301026	BTW BASE	盖板	(1)	262-60109
63		40312125	BTW CAM PLATE	控制板	(1)	262-60208
64		40302012	BTW SHAFT	梭芯轴	(1)	262-60901
65		40302013	BTW LEVER SHAF	转动轴	(1)	262-61008
66		40312126	BTW LEVER	绕线板手	(1)	262-61107
67		403S11052	SCREW	螺钉	(1)	SM-5040655-SN
68		40328038	WASHER 4.5X10X0.8	垫片	(1)	WP-0450826-SC
69		40302014	BTW BASE SHAFT	绕线定位轴	(1)	262-60307
70		40324015	BTW BEARING	轴承	(2)	262-61305
71		40304013	BTW SHAFT BASE	绕线转动曲柄	(1)	262-60406
72		40311021	BTW SPACER	梭芯轴垫	(1)	262-61206
73		40310008	BTW CAM LEVER	转动卡头	(1)	262-60505
74		403S14022	SCREW M5 L=5	螺钉	(1)	SM-8050502-TP
75		40303026	BTW WHEEL	绕线转动板	(1)	262-60604
76		403S14023	SCREW M4X8	绕线转动板螺钉	(2)	SM-8040802-TP
77		40327023	BTW TORSION SPRING	弹簧	(1)	262-60703
78		40322030	BTW WHEEL RUBBER	O形圈	(1)	262-61503
79		401s30016	SCREW	螺钉	5	-----
80		40122016	RUBBER PLUG	橡皮塞	5	TA-1050504-R0
81		40322014	NEEDLE BAR UPPRER BUSH CAP	针杆油塞	1	229-01409
83		40330025	LED	LED灯	1	-----
84		40311030	BED FITTING BASE	油盘	1	-----

2. MAIN SHAFT & NEEDLE BAR COMPONENTS

上轴针杆部件

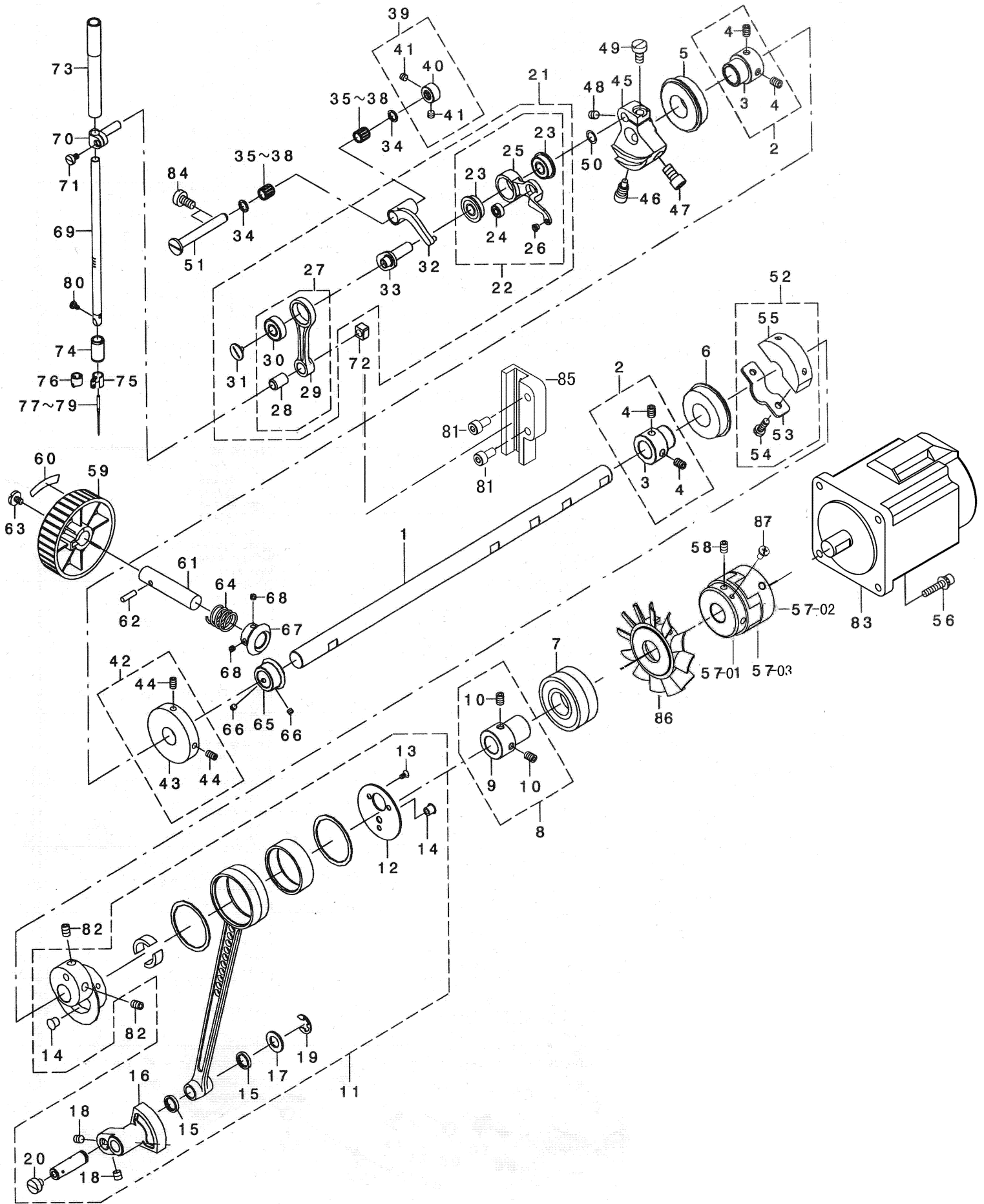

序号	注解	公司件号	DESCRIPTION	名称	用量	同类编号
1		40302007	MAIN SHAFT	上轴	1	400-10572
2		-----	BEARING BUSH -A-ASM	轴承套组件	2	400-10415
3		40303012	BEARING BUSH -A	轴承套	(2)	400-10416
4		403S14005	SCREW M6 L=8	轴承套螺钉	(4)	SM-8060812-TP
5		B10002	BEARING	上轴轴承(前)	1	SB-1200018-00
6		B10002	BEARING	上轴轴承(后)	1	SB-1200018-00
7		40324004	BEARING	轴承	1	SB-1200017-00
8		-----	BEARING BUSH -B-ASM	轴承套组件	1	400-10418
9		40303013	BEARING BUSH -B	轴承套	(1)	400-10419
10		403S14005	SCREW M6 L=8	轴承套螺钉	(2)	SM-8060812-TP
11		-----	CRANK-ROD-ALL-ASM	连杆组件	1	400-31136
12		40312064	CRANK-ROD-SUPPORT-PLATE	连杆挡板	(1)	400-10421
13		403S17001	SCREW M3 L=6	连杆挡板螺钉	(3)	SM-1030601-SP
14		40322023	PLUG D=6.7 L=6	挡板油塞	(2)	TA-0670604-R0
15		40322024	OIL SEAL	油塞	(2)	101-08009
16		42325002	OSCILLATOR	摆齿	(1)	400-06561
17		40312065	WASHER	垫片	(1)	400-26818
18		403S14006	SCREW	摆齿螺钉	(2)	SM-8480652-TP
19		H05008	E-SHAPEDSNAP RING (8mm)	卡簧	(1)	RE-0800000-K0
20		403S11021	SCREW M6 L=4.5	摆齿轴螺钉	(1)	SM-6060550-TP
21		4033800200	THREAD TAKE UP COMPL	挑线连杆组件	1	400-06529
22		-----	THREAD TAKE UP LEVER ASM	挑线杆组件	(1)	400-06530
23		40324005	BEARING	轴承	(2)	SB-1080022-00
24		40324006	BEARING	轴承	(1)	SB-1040016-00
25		40338003	THREAD TAKE UP LEVER	挑线杆	(1)	400-06531
26		40313008	THREAD PASS BUSH	过线管	(1)	B1908-505-000
27		-----	NEEDLE BAR CRANK ROD ASM	针杆连杆组件	(1)	400-06534
28		40303014	NEEDLE BAR CRANK ROD METAL	连杆套	(1)	228-91006
29		40305011	NEEDLE BAR CRANK ROD	针杆连杆	(1)	400-06535
30		40324007	BEARING	连杆轴承	(1)	SB-1080023-00
31		403S30011	LEFT SCREW	螺钉	(1)	B1903-552-000
32		40305012	THREAD TAKE UP CRANK	驼背连杆	(1)	400-06532
33		40304008	NEEDLE ROD CRANK	挑线曲柄	(1)	400-06537
34		40322025	BEARING SUPPORT	封油垫片	2	228-91204
35		40324008	BEARING	滚针轴承	2	SB-3070002-0A
36		-----	BEARING	滚针轴承	2	SB-3070002-0B
37		-----	BEARING	滚针轴承	2	SB-3070002-0C
38		-----	BEARING	滚针轴承	2	SB-3070002-0D
39		-----	THRUST-COLLAR-ASM	挡圈组件	1	400-10434
40		40308007	THRUST-COLLAR	挡圈	(1)	400-10435
41		403s14007	THRUST-COLLAR-SCREW	挡圈螺钉	(2)	400-10436
42		-----	BTW-DRIVING-WHEEL-ASM	饶线轮组件	1	400-10533
43		40335002	BTW-DRIVING-WHEEL	饶线轮	(1)	400-10534
44		403s14008	BTW-DRIVING-WHEEL SCREW	饶线轮螺钉	(2)	400-10533
45		40310005	COUNTER WEIGHT	针杆曲柄	1	400-10423
46		403s13007	COUNTER WEIGHT SCREW A	曲柄定位螺钉	1	400-06517
47		403s13008	BOLT M8 L=12	曲柄紧固螺钉	1	SM-6081252-TP
48		403s14006	SCREW M6X0.75 L=6	挑线曲柄螺钉	1	SM-8480652-TP
49		403s11022	SCREW	螺钉	1	SM-6061200-SP
50		40328018	WASHER 11.6X8.2X0.6	垫片	1	WP-0820516-SP
51		40326034	THREAD-TAKE-UP-CRANK-SHAFT	挑线连杆销	1	400-11902
52		-----	CRANK-BALANCER-ASM	平行块组件	1	400-10437
53		40312066	CRANK-BALANCER-FIX-PLATE	固定板	(1)	400-10439
54		403s11023	CRANK-BALANCER-FIX-PLATE-SCREW	平行块螺钉	(2)	400-10440
55		40312067	AC SERVO MOTOR	平行块	(1)	400-10438
56		403s1300900	BOLT	电机安装螺钉	4	SL-6052592-TN
57-01		40301023	COUPLING 1	传动连接块	1	-----
57-02		40301024	COUPLING 2	传动连接块	1	-----
57-03		40322028	DAMPING RUBBER	减震橡胶	1	-----
58		403s14005	SCREW M6 L=8	连接块螺钉	4	SM-8060812-TP
59		40311003	PULLEY	手轮	1	B1212-210-D00
60		40337005	REVOLVING DIRECTION LABEL	标记	1	B1144-210-000
61		40326004	HAND PULLEY SHAFT	手轮轴	1	265-00306
62		P03002	SPRING PIN 4X14	销	1	PS-0400142-KH
63		403s11003	SET-SCREW	螺钉	1	A1230-500-00A
64		40327004	SPRING	弹簧	1	GAF-01007000
65		40325010	GEAR A	上轴转动齿轮	1	400-06515
66		403s14010	SCREW M4 L=3	手轮齿轮螺钉	2	SM-8040310-SS
67		40325011	GEAR B	手轮轴齿轮	1	400-06516
68		403s14010	SCREW M4 L=3	手轮轴齿轮螺钉	2	SM-8040310-SS
69		40302015	NEEDLE BAR	针杆	1	400-10573
70		40104002	NEEDLE BAR CLAMP	针杆连接柱	1	B1411-552-000
71		401s11014	SCREW 9/64-40 L=6	针杆连接柱螺钉	1	SS-6090670-TP
72		41709001	SLIDE BLOCK	滑块	1	B1414-555-000
73		40303015	NEEDLE ROD METAL	针杆上套	1	400-10441
74		40303016	NEEDLE ROD LOWER METAL	针杆下套	1	400-10442
75		40313009	THREAD GUIDE	下过线	1	400-10574
76		-----	NEEDLE BAR THREAD GUIDE	下过线	1	D1405-L7A-M00
77	01	40317011	NEEDLE DPX5 #11	机针DP×5 #11	1	MDP-500B2100
78	02	40117001	NEEDLE DPX5 #16	机针DP×5 #16	1	MDP-500B1101
79	03	40319006	NEEDLE DPX17 #19	机针DP×17 #19	1	MDP-500B1400
80		201S11005	SCREW M1/8×44 L=5.5	支针螺钉	1	-----
81		403s13015	SCREW M4 L=16	导向螺钉	2	SM-8480652-TP
82		403S14005	SCREW M6 L=8	偏心轮螺钉	2	SM-8060812-TP
83		40333004	AC SERVO MOTOR	上轴电机	1	400-28015
84		403S14005	SCREW M6 L=8	螺钉	2	SM-6061250-TP
85		41709002	SLIDE BLOCK	滑块导向	1	-----
86		40311302	FAN	风扇	1	-----
87		403s13011	SCREW M6 L=8	螺钉	3	-----

NOTE (注释): 01、.....FOR 1900BM/BF 1900BM/BF用
02、.....FOR 1900BS 1900BS专用
03、.....FOR 1900BH 1900BH专用

3. PRESSER LIFTER & WIPER COMPONENTS

抬压脚及拨线部件

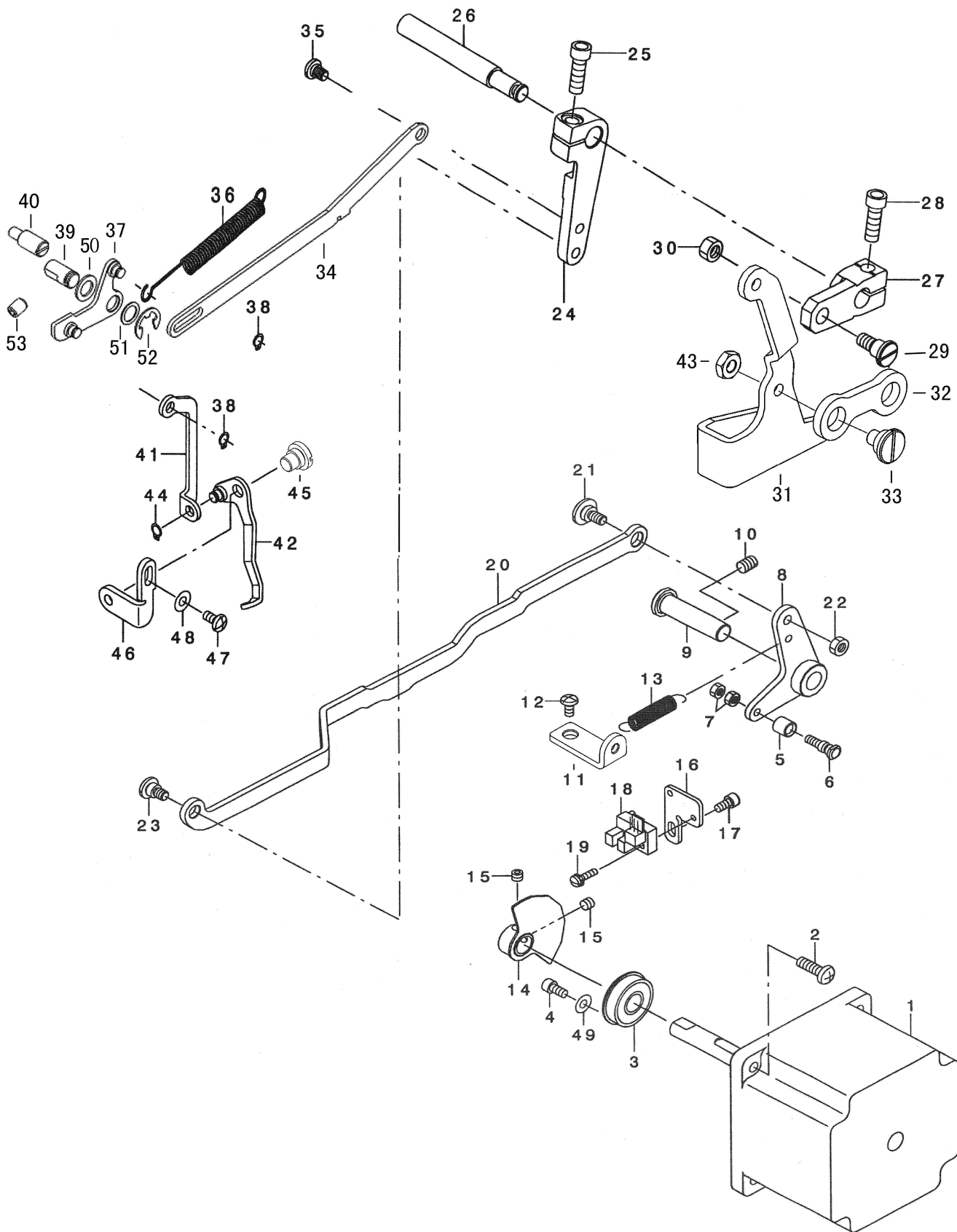

序号	注解	公司件号	DESCRIPTION	名称	用量	同类编号
1		40333013	PRESSER LIFTING MOTOR	剪线电机	1	-----
2		403S11026	SCREW M5 L=16	剪线电机螺钉	4	-----
3		40324009	BTW BEARING	轴承6000ZZNR	1	SB-1100024-00
4		403S13011	SCREW M4 L=8	螺钉	1	SM-6040802-TP
5		40303017	NEEDLE CAM ROLLER A	滚筒	1	235-17501
6		403S20009	CAM ROLLER SHAFT	轴位螺钉	1	400-40256
7		403S16005	NUT M4X0.7	螺母	2	NM-6040001-SP
8		40312068	LIFTER LINK A ASM.	拨线曲柄	1	400-06661
9		40326016	CONNECTING SHAFT	拨线曲柄轴	1	400-06716
10		403S14005	SCREW M6 L=8	轴承套螺钉	1	SM-8060812-TP
11		40312069	HOOK COVER PUSH SPRING	拉簧板	1	-----
12		403S11027	HOOK COVER PUSH SPRING SCREW	拉簧板螺钉	1	SM-4040855-SP
13		40127019	SPRING	弹簧	1	135-15606
14		4031211800	SENSOR SLIT ASM	拨线传感器组件	1	-----
15		403s14012	SCREW M5 L=4	螺钉M5×4	2	SM-8040412-TP
16		40312071	SENSOR INSTALLING BASE	传感器安装板	1	400-10443
17		403S13011	SCREW M6 L=18	螺钉	1	SM-6040802-TP
18		40330005	PHTO SENSOR	传感器	1	HD-0005700-OA
19		403S11044	HINGE SCREW D=7 H=4	传感器螺钉组件	1	-----
20		42312011	LIFTER LINK B	拨线杆	1	400-06665
21		403S20010	HINGE SCREW D=8 H=3.2	拨线杆轴位螺钉	1	SD-0800327-TP
22		403S16006	NUT M5	螺母	1	NM-6050001-SP
23		403S20011	SCREW M6 L=18	螺钉	1	SD-0700406-TP
24		40305013	CONNECTING ARM	拨线转动曲柄	1	400-06671
25		S05030	SCREW M6 L=18	M6×18内六角螺钉 GB/T70.1-2008	1	SM-6061802-TP
26		40326017	CONNECTING SHAFT	曲柄轴	1	265-00405
27		400330	LOWERING ARM	拾压脚曲柄	1	-----
28		S05030	SCREW M6 L=18	M6×18内六角螺钉 GB/T70.1-2008	1	SM-6061802-TP
29		403S20012	HINGE SCREW D=7.94 H=6	拾压曲柄螺钉	1	SD-0790606-TP
30		403S16007	NUT M6	拾压曲柄螺母	1	NM-6060001-CP
31		42312008	LOWERING FOOT	拾压脚传动杆	1	240549-920
32		40312008	CONNECTING LINK	连接杆	1	141-04400
33		403S20013	HINGE SCREW D=10 H=4	拾压脚小连杆螺钉	1	SD-1000406-TP
34		40312151	WIPER CONNECTING LINK	扫线调节杆	1	-----
35		403S20014	WIPER -STOPPER	螺钉	1	SD-0600206-TP
36		40127011	SPRING	弹簧	1	135-09708
37		4031215200	WIPER CONNECTING-ARM-ASM	扫线连接板组件	1	251345
38		40108011	THRUST COLLAR ASM	挡圈4.7	2	RC-0470611-KP
39		40326039	WIPER CONNECTING-LINK-SHAFT	扫线连接板销	1	-----
40		403S13021	WIPER -STOPPER	螺钉	1	-----
41		40312154	WIPER CONNECTING-PLATE	扫线连接拉板	1	-----
42		4031207700	WIPER C ASM	扫线杆组件	1	400-17202
43		403S16008	NUT M6	螺母	1	NM-6060003-SC
44		40108004	THRUST COLLAR ASM	E形挡圈4	1	RC-0470611-KP
45		403S20016	HINGE SCREW D=6.35 H=2.1	螺钉	1	SD-0640216-TP
46		40312078	WIPER BASE PLATE	扫线杆固定架	1	-----
47		403S11027	HINGE SCREW D=6.35 H=2.1	拉簧板螺钉	1	SM-4040855-SP
48		40328019	WASHER	垫片	1	WP-0450801-SP
49		40328019	WASHER	垫片	1	WP-0450802-SP
50		40328042	WASHER	垫片	1	240101
51		40328018	WASHER	垫片	1	WP-0820516-SP
52		40129001	RETAINING RING 4.7	卡簧	1	RE-0600000-KQ
53		403s13013	SCREW M5 L=6	螺钉	1	-----

4. SHUTTLE DRIVER SHAFT COMPONENTS

下轴部件

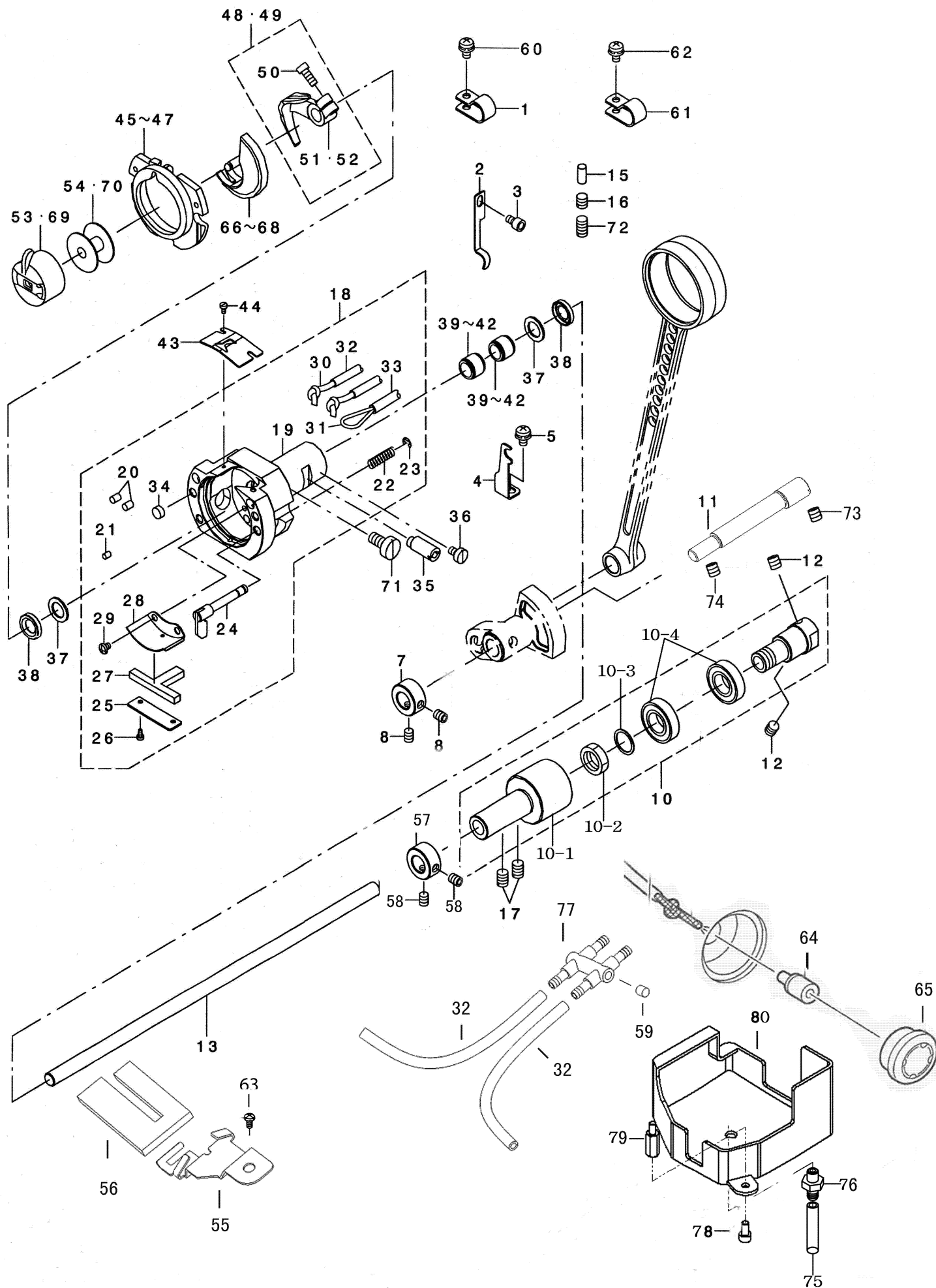

序号	注解	公司件号	DESCRIPTION	名称	用量	同类编号
1		40311015	CABLE CLIP	油管夹	1	HX-0015000-0D
2		40312079	OIL-PIPE-HOLDER	油管压板	1	400-12127
3		403s13013	SCREW M4 L=6	油管压板螺钉	3	SM-6040602-TP
4		40312080	TUBE-CLAMP	油管夹板	1	400-13721
5		403s11028	SCREW M4 L=8	螺钉	1	SL-4040891-SC
6		-----	THRUST-COLLAR-ASM.	挡圈组件	1	400-10464
7		40308008	THRUST-COLLAR	挡圈	(1)	400-10467
8		403s14013	THRUST-COLLAR-SCREW	螺钉	(2)	400-10469
9		-----	-----	-----	-----	-----
10		4030302000	LOWER-SHAFT-GEAR-ASM.	轴承套组件	1	400-16077
10-01		42303001	LOWER-SHAFT-GEAR	轴承套	1	-----
10-02		403s16011	NUT M12X1	螺母	1	-----
10-03		40328024	WASHER	垫圈	1	-----
10-04		11424001	BEARING	轴承	2	-----
10-05		40325015	GEAR	下轴齿轮	1	-----
11		42302004	OSCILLATOR SHAFT	偏心轴	1	-----
12		403s11016	SCREW M6 L=6	螺钉	2	SM-8060612-TP
13		40302009	LOWER SHAFT	下轴	1	400-10575
14		40111005	CABLE BAND	紧线带	2	EA-9500B01-00
15		40322026	OIL WICK PRESSER	橡皮塞	1	400-06578
16		403s14014	SCREW	油量调节压块螺钉	1	SM-8060610-TP
17		403s14005	SCREW M6 L=8	螺钉	2	SM-8060812-TP
18		4031800700	SHUTTLE ASM.	梭床组件	1	400-06573
19		40318010	SHUTTLE	梭床	(1)	400-06574
20		-----	SHUTTLE OIL FELT A	油棉塞	(2)	B1820-210-D00
21		-----	SHUTTLE OIL FELT A	橡皮塞	(1)	B1821-210-D00
22		40327007	INNER HOOK PRESSER SPRING	弹簧	(2)	B1822-215-P00
23		40129001	E-RING 3	卡簧	(2)	RE-0300000-K0
24		40326008	INNER HOOK PRESSER SPRING	梭床盖压柱	(2)	265-01858
25		40312021	ONCE THROUGH OIL FELT PRESSER	油毡压板	(1)	141-04004
26		403s11029	SCREW M2 L=3.5	螺钉	(2)	SM-6020460-TP
27		40323002	SHUTTLE ONCE THROUGH OIL FELT	梭床油毡	(1)	141-03907
28		40312120	SHUTTLE LUBRICATING PLATE	梭床润滑压板	(1)	400-06577
29		403s11046	SCREW	螺钉	(2)	SM-4030455-SP
30		12923018	OIL WICK	油绳	(2.6)	CQ-2000000-00
31		12923018	OIL WICK	油绳	(1.4)	CQ-2000000-00
32		12921002	TUBE	油管	(1)	236-30007
33		-----	TUBE	油管	(0.6)	236-30007
34		40322029	SHUTTLE PACKING	油棉塞	(2)	135-29607
35		40326019	SHUTTLE -PACE-ADJUSTING	梭床座调节销	1	400-10471
36		403s11011	SCREW M4 L=6	梭床座紧固螺钉	1	SM-6040650-TP
37		40328020	SHUTTLE BEARING RING	垫片	2	400-06575
38		40322031	SHUTTLE OIL SEAL	油封	2	400-06576
39		40324010	BEARING	滚针轴承	2	SB-3080010-0A
40		-----	BEARING	滚针轴承	2	SB-3080010-0B
41		-----	BEARING	滚针轴承	2	SB-3080010-0C
42		-----	BEARING	滚针轴承	2	SB-3080010-0D
43		40327014	INNER HOOK UPPER SPRING	梭床分线片	1	B1815-210-000
44		403s11029	SCREW M2 L=3.5	螺钉	2	SM-6020460-TP
45		-----	INNER HOOK PRESSER ASM. A.	梭床盖	1	141-03253
46		-----	INNER HOOK PRESSER ASM. B.	梭床盖	1	141-03352
47		40318004	INNER HOOK PRESSER ASM. C.	梭床盖	1	141-03659
48		-----	DRIVER ASM.	摆梭托组件	1	400-11512
49		-----	SHUTTLE DRIVER ASM.	摆梭托组件	1	400-14963
50		401s13005	SCREW 3/16-28 L=12.0	螺钉	(1)	SS-6121212-TP
51		40118503	SHUTTLE-DRIVER	摆梭托	(2)	400-11511
52		-----	SHUTTLE-DRIVER	摆梭托	(3)	400-10879
53		40118502	BOBBIN CASE ASM. (RACING PREVE)	梭壳	1	B1828-980-0BB
54		40118004	BOBBIN	梭心	1	138-12102
55		42312018	OIL WICK PRESSER	油毡夹	1	400-10473
56		40323004	LOWER SHAFT-GEAR-FELT	油毡	(1)	400-10474
57		40108005	THRUST COLLAR ASM	拉力环	1	CS-080081C-SH
58		201s14002	SCREW	螺钉	2	151602002
59		41722016	SHUTTLE OIL FELT A	橡胶塞	1	142274101
60		403s11028	SCREW M4 L=8	螺钉	1	SL-4040891-SC
61		40311016	CABLE CLIP	电线夹	2	HX-0015000-0B
62		403s11028	SCREW M4 L=8	电线夹螺钉	2	SL-4040891-SC
63		403s11011	SCREW M5 L=8	油夹螺钉	1	SM-4050855-SP
64		41736002	TERMINAL	油管嘴	1	-----
65		4171100300	OIL TANK ASM.	油窗组件	1	-----
66	01	40118501	SHUTTLE	梭托	1	400-06580
67	02	40318501	SHUTTLE (H)	梭托	1	-----
68		-----	SHUTTLE (H)	梭托	1	-----
69		-----	BOBBIN CASE ASM.	梭壳	1	-----
70		-----	BOBBIN	梭心	1	-----
71		403s11030	SHUTTLE-ASM-SCRERW	梭床固定螺钉	1	400-10470
72		403s14021	SCREW	螺钉	1	SM-8061050-TP
73		403s14027	SCREW	螺钉	1	HH0282004
74		403s14027	SCREW	螺钉	1	HH0282004
75		12921005	TUBE	回油管	1	-----
76		12936003	TERMINAL	油管接头	1	-----
77		42311002	TERMINAL L	管接头L	1	-----
78		403s13011	SCREW	螺钉	2	-----
79		413s30021	SCREW	加长螺钉	2	-----
80		40311031	BED FITTING BASE	小油盘	1	-----

NOTE(注释): 01、.....FOR 1900BS 1900BS专用
02、.....FOR 1900BH 1900BH专用

5. THREAD TENSION COMPONENTS

紧线部件

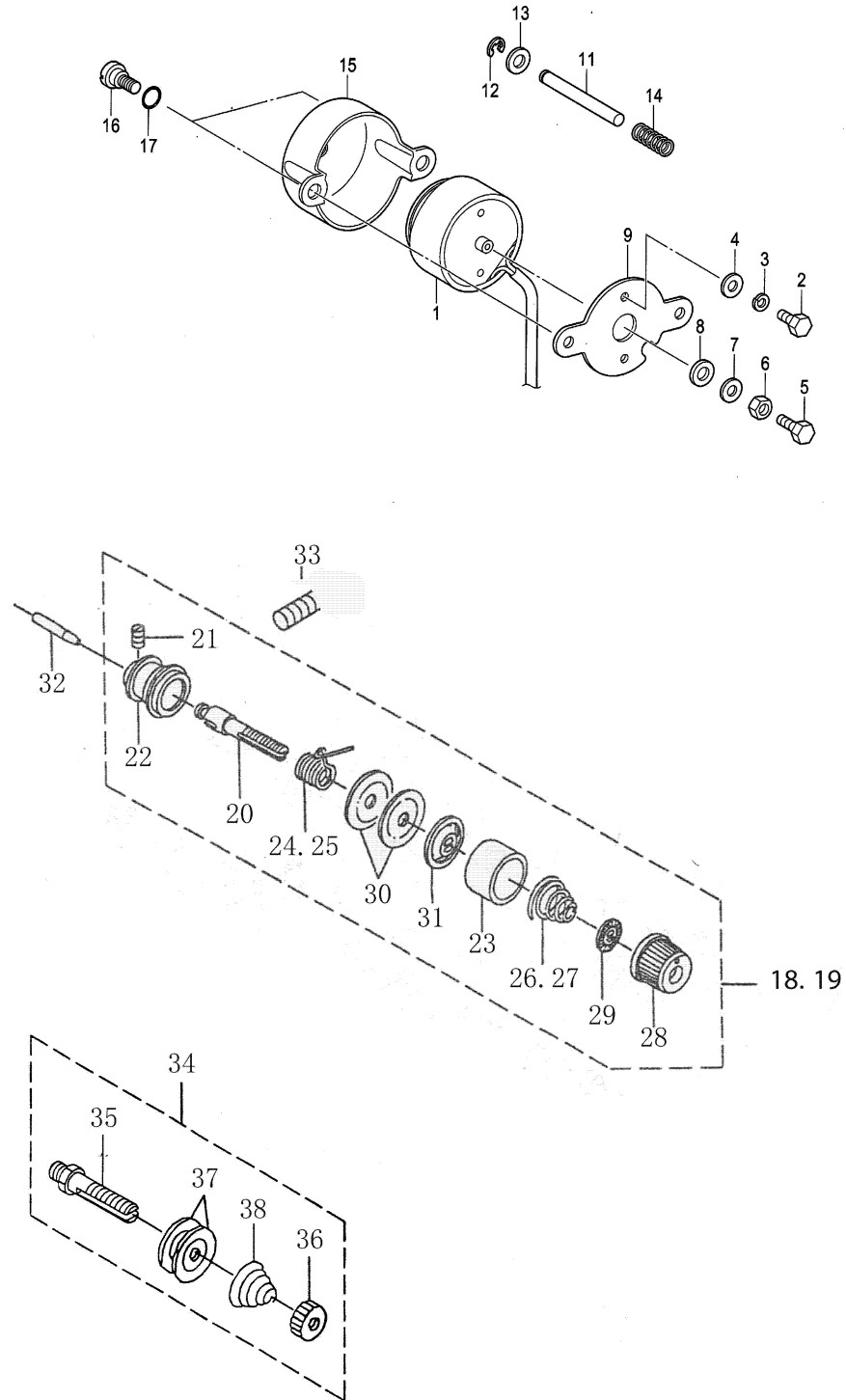

序号	注解	公司件号	DESCRIPTION	名称	用量	同类编号
1		41730004	TENSION RELEASE SOLENOID HV	松线电磁铁HV	1	SA4855001
2		L02031	BOLT M4X8	螺栓 M4X8	1	017400802
3		W02008	WASHER SPRING 2-4	弹簧垫圈 2-4	1	028040246
4		W01001	WASHER PLANT M4	平垫圈 M4	2	025040236
5		L02036	BOLT M4X14	螺栓 M4X14	2	017401415
6		N01024	NET 3 M4	六角螺母 M4	2	021400306
7		W01001	WASHER PLANT M4	平垫圈 M4	1	025040236
8		41722020	SOLENOID CUSHION	电磁铁缓冲垫圈	1	154599000
9		41712099	SETTING PLATE SOLENOID	电磁铁安装板	1	SA6389001
10		-----	-----	-----	-----	-----
11		40326041	TENTION RELEASE BAR	松线杆	1	-----
12		H05029	RATAINING RING E4	挡圈 E4	1	048040342
13		W01009	WASHER PLANT M5	平垫圈 M5	1	025050236
14		41727013	SPARING COMPRESSION	弹簧	1	SA3348001
15		41711013	SOLENOID COVER	松线电磁铁外罩	1	SA3349002
16		417s30012	SHOULDE SCREW 7-3	段螺钉7-3	1	SA3306001
17		41722021	O RING P7	O型圈P7	1	081007070
18	01	4013100300	SECOND THREAD TENTION ASM.	夹线器组件	1	-----
19	02	4033100500	SECOND THREAD TENTION ASM.	夹线器组件	1	-----
20		40126009	SECOND THREAD TENTION ROD	张力柱(二号)	1	B2302-280000
21		401s15005	SCREW 9/64-40 L=5.9	螺钉9/64-40 L=5.9	1	SS-8090610-SP
22		40103010	THREAD TENTION ROD. LARGH	张力柱孔	1	B2313-280000
23		40112028	THREAD TENTION DISK PRESSER	张力圆盘压力管	1	B3107-804000
24		40127007	THREAD TAKE-UP SPRING	紧线器弹簧	1	B3112-761000
25		-----	-----	-----	-----	-----
26		40127008	TENTION SPRING	拉力弹簧	1	B3114-232000
27		-----	-----	-----	-----	-----
28		40111004	THREAD TENTION NUT	张力器帽盖	1	B3119-771000
29		40112029	ROTATING STOPPER	张力弹簧止动器	1	B3120-125000
30		A40112026	THREAD TENTION DISK	张力圆盘	2	B1326-012000
31		40112027	THREAD TENTION DISK PRESSER	张力圆盘固定器	1	B3132-552000
32		40126007	TENTION RELEASE PIN	张力释放销	1	-----
33		403S14016	SCREW M6×16	夹线器固定螺钉	1	-----
34		4013100400	FIRT THREAD TENTION ASM.	张力控制器	1	-----
35		40126010	THREAD TENTION ROD	张力柱(一号)	1	B3123-352000
36		401s16010	THREAD TENTION NUT	拉伸螺母	1	B3125-012000
37		40112016	THREAD TENTION DISK	张力圆盘	2	B3126-012000
38		40127009	TENTION SPRING	拉伸弹簧	1	B1115-232000

NOTE(注释): 01、.....FOR 1900BS 1900BS专用
 02、.....FOR 1900BH 1900BH专用

6. THREAD TRIMMER MECHANISM COMPONENTS

剪线部件

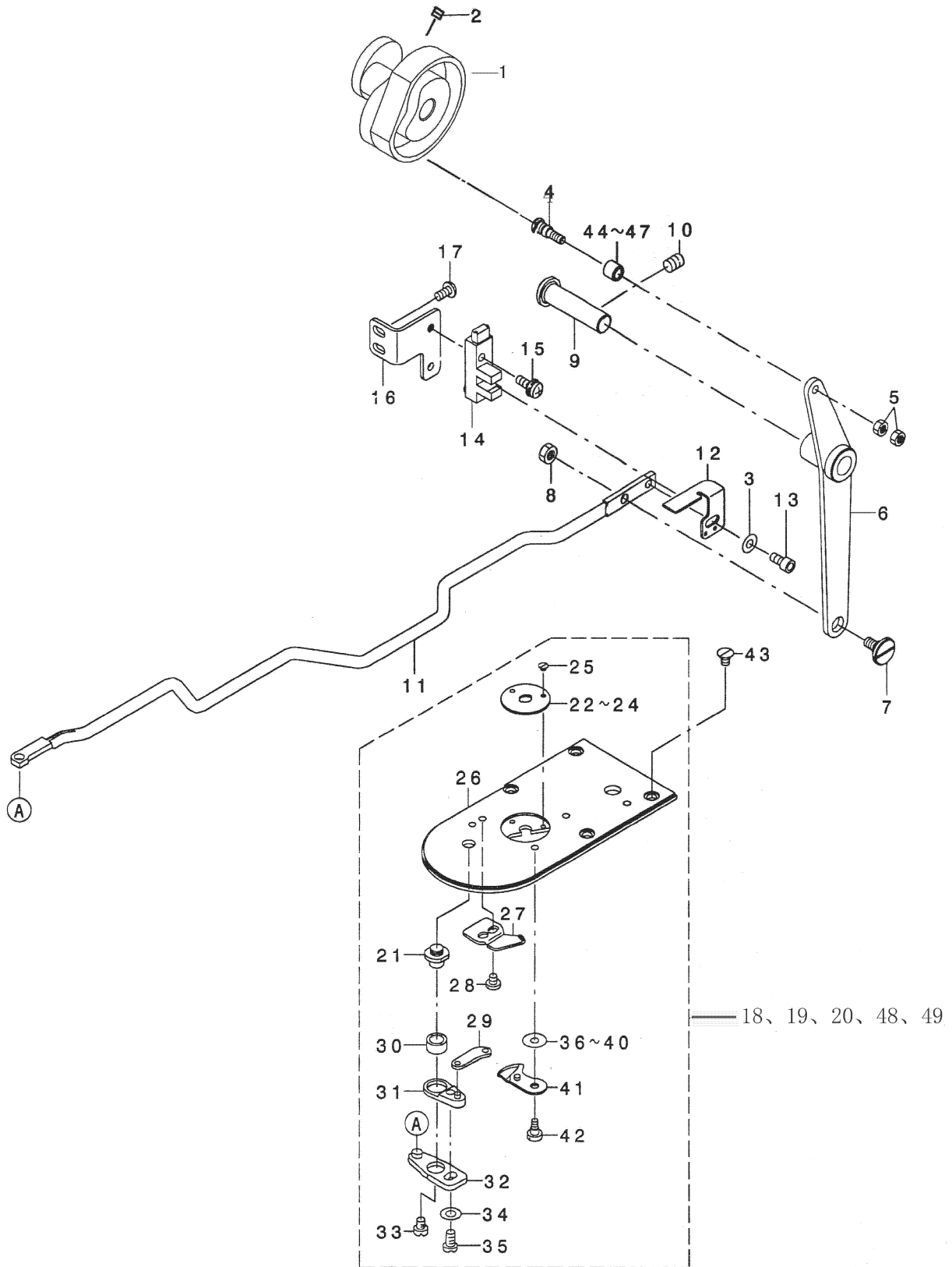

序号	注解	公司件号	DESCRIPTION	名称	用量	同类编号
1		42310001	THREAD TRIMMER CAM	剪线凸轮	1	400-06711
2		403s14017	SCREW	螺钉	2	SM-8050592-TP
3		40328019	WASHER	垫片	1	WP-0450801-SP
4		403s20009	CAM ROLLER SHAFT	螺钉	1	400-40256
5		403s16005	NUT M4X0.7	螺母	2	NM-6040001-SP
6		40312101	THREAD TRIMMER LINK ASM.	连接板	1	400-06712
7		403s20010	HINGE SCREW D=8 H=3.2	螺钉	1	SD-0800327-TP
8		403s16006	NUT M5	螺母	1	NM-6050001-SP
9		40326016	THREAD TRIMMER SHAFT	固定销	1	400-06716
10		403s14005	SCREW M6 L=8	螺钉	1	SM-8060812-TP
11		40312089	CONNECTING BAR	连接轴	1	400-06717
12		40312090	THREAD-TRIMMER-SENSOR-SLIT	感光片	1	400-10525
13		403s13013	SCREW M4X0.7 L=6	螺钉	1	SM-6040802-TP
14		40330022	PHOTO SENSOR	传感器	1	HD-0022300-00
15		S01003	SCREW M4 L=12	传感器固定螺钉	1	SL-4041291-SC
16		40312091	THREAD-TRIMMER-SENSOR-BASE	传感器固定板	1	400-10526
17		403s11027	SCREW	螺钉	2	SM-4040855-SP
18	01	4031501400	NEEDLE PLATE ASM. , A	针板组件	1	400-06722
19	02	4031501500	NEEDLE PLATE ASM. , H	针板组件	1	400-06723
20	03	4031501600	NEEDLE PLATE ASM. , E	针板组件	1	400-06724
21		403S30004	THREAD CUTTER LEVER SHAFT	切线摇杆螺钉	(1)	B2417-280-000
22		40115002	NEEDLE HOLE GUIDE	针孔板	(1)	B2426-280-000
23		-----	NEEDLE HOLE GUIDE	针孔板	(1)	141-09607
24		-----	NEEDLE HOLE GUIDE	针孔板	(1)	B2426-282-C00
25		401S17006	SCREW 3/32-56 L=2.2	开槽沉头螺钉	(2)	SS-1060210-TP
26		40315013	NEEDLE PLATE	针板	(1)	400-06721
27		40119002	FIXING KNIFE	固定刀片	(1)	B2424-280-000
28		401S11020	SCREW 9/64-40 L=3.5	螺钉	(2)	SS-7090410-SP
29		40105003	MOVING KNIFE LINK	转刀连接杆	(1)	B2418-280-000
30		40103009	THREAD CUTTER LEVER RING	转刀连接环	(1)	B2416-280-000
31		4011202000	THREAD CUTTER LEVER ASM. , SMALL	转刀驱动杆组件	(1)	B2415-280-0A0
32		4011202200	THREAD CUTTER LEVER ASM. , LARGE	转刀驱动架组件	(1)	B2414-280-0A0
33		401S20008	SCREW 11/64-40 L=4.0	螺钉11" /64-40、L=4.0	(1)	SS-6110430-TP
34		40128008	WASHER	垫圈	(1)	WP-0450846-SP
35		401S11021	SCREW 11/64-40 L=7	螺钉11" /64-40、L=7	(1)	SS-7110740-TP
36		40128009	MOVING KNIFE WASHER C	转刀垫圈	(1)	B2423-280-00C
37		-----	MOVING KNIFE WASHER A	转刀垫圈	(1)	B2423-280-00A
38		-----	MOVING KNIFE WASHER B	转刀垫圈	(1)	B2423-280-00B
39		-----	MOVING KNIFE WASHER D	转刀垫圈	(1)	B2423-280-00D
40		-----	MOVING KNIFE WASHER E	转刀垫圈	(1)	B2423-280-00E
41		40119001	MOVING KNIFE ASM.	转刀	(1)	B2421-280-0A0
42		401S20007	HINGE SCREW D=5 H=0.9	合叶螺丝D=5.0 H=0.9	(1)	SD-0500091-TP
43		403S17002	SCREW M4 L=6	针板螺钉	4	SM-1040650-TP
44		40303019	NEEDLE CAM ROLLER A	滚珠	1	263-15606
45		-----	NEEDLE CAM ROLLER B	滚珠	1	263-15705
46		-----	NEEDLE CAM ROLLER C	滚珠	1	263-15804
47		-----	NEEDLE CAM ROLLER D	滚珠	1	263-15903
48	04	4231500300	NEEDLE PLATE ASM.	针板组件	1	-----
49		-----	NEEDLE PLATE ASM. H	针板组件	1	-----

NOTE (注释): 01、.....FOR 1900BS 1900BS专用
02、.....FOR 1900BH 1900BH专用
03、.....FOR 1900BM/BF 1900BM/BF用
04、.....FOR 1906BS 1904BS、1906BS用

7. FEED MECHANISM COMPONENTS

送料部件

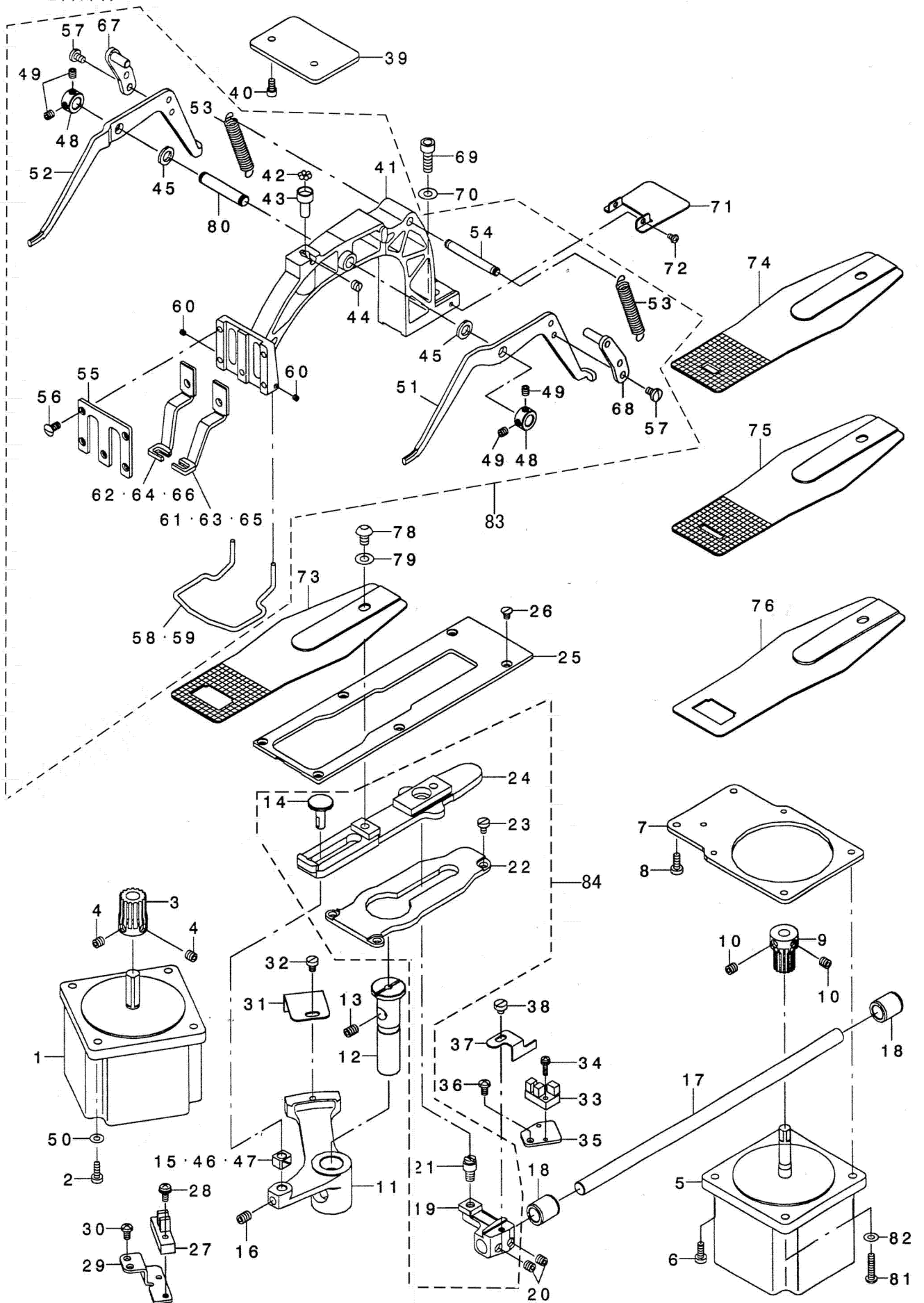

序号	注解	公司件号	DESCRIPTION	名称	用量	同类编号
1		40333014	X FEED MOTOR	X轴步进电机	1	400-29901
2		403s13016	SCREW M4 L=16	螺钉	2	SM-4041655-SP
3		40325012	X FEED GEAR	横向供给齿轮	1	265-01403
4		403s14018	SCREW M6X6	螺钉	2	SM-8060602-TP
5		40333015	Y FEED MOTOR	Y轴步进电机	1	400-29902
6		403s11015	SCREW M4 L=11	螺钉	2	SM-6041150-TP
7		40312092	Y- FEED-MOTOR-BASE	Y轴电机固定板	1	400-10536
8		403s11015	SCREW M4 L=11	螺钉	2	SM-6041150-TP
9		40325013	Y FEED GEAR	Y轴送料齿轮	1	265-01502
10		403s14018	SCREW M6X6	Y轴送料齿轮螺钉	2	SM-8060602-TP
11		40325014	CLOTH FEED ARM	横向供给摇杆	1	400-06736
12		40326011	FEED DRIVING ARM SHAFT	供给摇杆轴	1	135-16208
13		403s14005	SCREW M6X8	螺钉	1	SM-8060812-TP
14		40326020	SLIDE BLOCK STUD	滑块连接销	1	262-23305
15		40309003	SQUARE BLOCK	滑块	1	B1414-232-000
16		403s14005	SCREW M6X8	螺钉	1	SM-8060812-TP
17		40325016	Y FEED SHAFT	Y向送料轴	1	400-06738
18		40303007	BUSHING , REAR	轴套	2	B2509-704-000
19		40304009	Y FEED ARM	Y向送料曲柄	1	265-00009
20		116S14004	SCREW 1/4-40 L=6	螺钉	2	SS-8660612-TP
21		401S20018	HINGE STUD	铰链销	1	135-17404
22		40312093	CLOTH FEED SUPPORT PLAE	供给支架压板	1	400-06740
23		403S11011	SCREW	供给压板螺钉	3	SM-6040650-TP
24		40304010	CLOTH FEED PLATE	横向供给支架	1	400-06737
25		40312094	CLOTH FEED PRESSER PLATE	供给压板	1	400-06739
26		403S17002	SCREW M4 L=6	供给压板螺钉	4	SM-1040650-TP
27		40330022	PHOTO SENSOR	X向感应器	1	HD-0022300-00
28		403s11043	SCREW MAXO. 7 L=12	X向感应器螺钉组件	1	SL-4041281-SC
29		40312035	SENSOR I NSTALLING BASE	X向感应器固定板	1	141-11702
30		403s11027	SCREW	螺钉	2	SM-4040855-SP
31		40312139	CROSSFEED SENSOR SLIT	X向感光板	1	141-11504
32		403S11011	SCREW M4 L=6	X向感光板螺钉	1	SM-6040650-TP
33		40330010	PHOTO SENSOR	Y向感应器	1	HD-0005700-0A
34		403s11044	SCREW M3 L=12	Y向感应器螺钉组件	1	SL-4031291-SC
35		40312037	SENSOR I NSTALLING BASE	Y向感应器固定板	1	141-11801
36		403s11027	SCREW	螺钉	1	SM-4040855-SP
37		40312036	LENGTHWISE FEED SENSOR SLIT	Y向感光板	1	141-36402
38		401S11024	SCREW 11/64-40 L=4.3	螺钉	1	SS-6110480-SP
39		40312095	SUPPORT PLATE	支架板	1	400-39255
40		403s13011	SCREW M4X0.7 L=8	螺钉	2	SM-6040802-TP
41		40301020	FEED BRACKET B	供给架	1	400-39013
42		40109004	WORK CLAMP FOOT MOUNTING BASE	钢珠	5	B2549-280-000
43		40126021	BALL REATINER	钢珠护轴	1	B2548-280-000
44		401S15007	SCREW 15/64-28 L=4.7	螺钉	1	SS-8150510-TP
45		40128012	WASHER FOR DRIVING ARM	垫片	2	B2557-280-00A
46		-----	CRANK SLIDE BLOCK	滑块	1	B1414232-00A
47		-----	GUIDE ROLLER	滑块	1	B1414232-00B
48		40308010	THRUST COLLAR	挡圈	2	CS-0800881-TP
49		403s14019	SCREW M5 L=5	螺钉	4	SM-8050512-TP
50		40328019	WASHER	垫片	4	WP-0450801-SP
51		40312096	LIFTING LEVER RIGHT	上升杆(右)	1	262-04008
52		40312097	LIFTING LEVER LEFT	上升杆(左)	1	262-04107
53		40127027	CLOTH PRESSER SPRING	拉簧	2	141-05407
54		40126022	SPRING SUSPENSION	拉簧钩轴	1	135-18501
55		40112051	WORK CLAMP FOOT FACE PLATE	压脚固定板	1	135-18808
56		401S17007	SCREW 11/64-40 L=8.7	螺钉	5	SS-2110930-SP
57		401S11021	SCREW 11/64-40 L=7	螺钉	4	SS-7110740-TP
58		40127017	FINGERGUAARD	护指簧	1	135-33104
59		-----	FINGERGUAARD	护指簧	1	135-48300
60		401S15008	SCREW 1/8-44 L=2.8	螺钉1"/8-44、L=2.8	2	SS-8080310-TP
61		40116004	WORK CLAMP FOOT , RIGHT	手工夹脚(右)	1	135-18600
62		40116001	WORK CLAMP FOOT , LEFT	手工夹脚(左)	1	135-18709
63		-----	WORK CLAMP FOOT , RIGHT	(右)压脚	1	135-48102
64		-----	WORK CLAMP FOOT , LEFT	(左)压脚	1	135-48201
65		-----	WORK CLAMP FOOT , RIGHT	(右)压脚	1	135-42915
66		-----	WORK CLAMP FOOT , LEFT	(左)压脚	1	135-43012
67		4031209800	LEVER DRIVING PLATE L ASM.	上升调节杆(左)	1	400-06745
68		4031209900	LEVER DRIVING PLATE R ASM.	上升调节杆(右)	1	400-06747
69		S05030	SCREW M6 L=18	螺钉M6X18	1	SM-6061802-TP
70		40128013	WASHER 6. 2X13X1	垫圈	1	WP-0621016-SD
71		40312100	HIDDEN-PLATE	供给架压板	1	400-10570
72		403s11035	SCREW M3 L=5	螺钉	2	SM-5030501-SC
73	01	40315001	FEED PLATE A	送料板A(标准)	1	141-16107
74	02	40315020	FEED PLATE B	送料板B	1	141-16206
75	03	40315012	FEED PLATE C	送料板C(厚料)	1	135-54803
76	04	40315021	FEED PLATE D	送料板D	1	141-16800
78		403S13002	SCREW M6 L=10	螺钉M6X10	1	SM-3061052-TP
79		40128013	WASHER 6. 2X13X1	垫圈	1	WP-0621016-SD
80		40326021	LIFTING LEVER SHAFT B	上升杆轴	1	400-39012
81		403s13016	SCREW M4 L=20	螺钉	2	SM-4042055-SP
82		40328019	WASHER	垫片	2	WP-0450801-SP
83		4030102900	FEED BRACKET ASM	供给架组件	1	-----

NOTE(注释):01、.....FOR 1900BS 1900BS专用
02、.....FOR 1900BM 1900BM专用
03、.....FOR 1900BH 1900BH专用
04、.....FOR 1900BF 1900BF专用

8、PRESSER MECHANISM COMPONENTS

中压脚部件 (JK-T1904B 和 JK-T1906B 专用部件1)

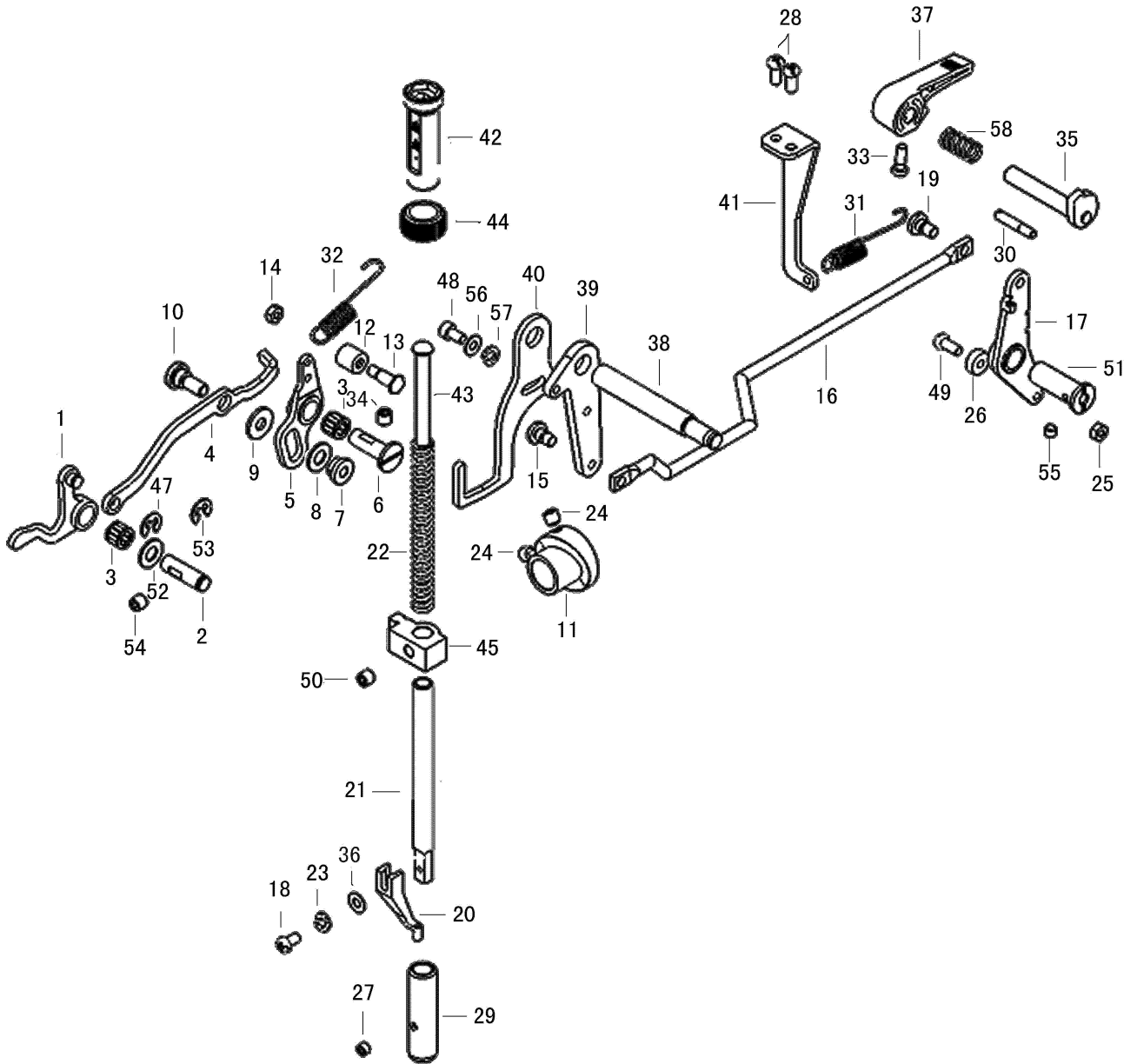

序号	注释	公司件号	DESCRIPTION	名称	用量	同类编号
1		42301001	STEPPING CLAMP LIFTER	压脚控制板	1	-----
2		42326002	ROLLER	轴销	1	-----
3		B08010	BEARING	滚针轴承	2	-----
4		42312007	STEPPING CLAMP LIFTER ROD	抬压脚连接杆	1	-----
5		42301002	ADJUSTING PLATE	中压脚调节板	1	-----
6		42326003	ROLLER	轴销	1	-----
7		423s16001	T NUT	T型螺母	1	-----
8		42328001	WASHER	垫圈	1	-----
9		42328002	WASHER	垫圈	1	-----
10		423s20002	SCREW	轴位螺钉	1	-----
11		42310002	CAM	凸轮	1	-----
12		B09006	BEARING	滚针轴承	1	-----
13		423s20003	SCREW	轴位螺钉	1	-----
14		409S16018	NUT 11/64	螺母11/64	1	-----
15		423s20004	SCREW	轴位螺钉	1	-----
16		42312014	CONNECTING BAR	中压脚连接杆	1	-----
17		42301003	LOWERING ARM	抬压曲柄板	1	-----
18		417s15011	SCREW M3. 57X12	螺钉M3. 57X12	1	-----
19		423s20005	SCREW	轴位螺钉	1	-----
20		41716001	WORK CLAMP	压脚	1	-----
21		41702018	PRESSER BAR	压紧杆	1	-----
22		42327002	PRESSER BAR SPRING	压簧	1	-----
23		40928021	WASHER	垫圈	1	-----
24		403S14017	SCREW	螺钉	2	-----
25		403s16004	NUT M4	螺母 M4	1	-----
26		B01017	BEARING	轴承	1	-----
27		s09006	SCREW M4X4	螺钉M4X4	1	-----
28		403s11027	SCREW	拉簧板螺钉 M4X8	2	-----
29		41703015	PRESSER BAR BUSH	压杆轴套	1	-----
30		423s30001	SCREW	限位螺钉	1	-----
31		42327001	SPRING	拉簧	1	-----
32		40227042	SPRING	拉簧	1	-----
33		124s30009	SCREW M3. 5X12	组合螺钉M3. 5X12	1	-----
34		403S14005	SCREW	螺钉M6X8	1	-----
35		4231200500	PRESSER FOOT WRENCH	压脚扳手凸轮组件	1	-----
36		W02008	WASHER	弹簧垫圈	2	-----
37		12411003	PRESSER FOOT WRENCH	抬压脚扳手	1	-----
38		40326017	CONNECTING SHAFT	曲柄轴	1	-----
39		42312002	ADJUSTING PLATE	调节板	1	-----
40		42312012	FOLLOWER ASM	拨勾	1	-----
41		42312013	HOOK COVER PUSH SPRING	弹簧拉板	1	-----
42		129s30003	ADJUSTING SCREW	调节螺栓M14	1	-----
43		41702017	PRESSER BAR SPRING GUIDE	弹簧导向	1	-----
44		129s16001	NUT	调节螺母M14	1	-----
45		42309002	PRESSER BAR CLAMP	压紧杆夹头	1	-----
46		-----	-----	-----	1	-----
47		H05003	E-SHAPEDSNAP RING 5	卡簧 E5	1	-----
48		413S11002	SCREW M5X10	螺钉 M5X10	1	-----
49		423s20006	SCREW	轴位螺钉	1	-----
50		403S14006	SCREW	螺钉	1	-----
51		42326004	ROLLER	轴销	1	-----
52		30128006	WASHER	垫圈	1	-----
53		40129001	E-SHAPEDSNAP RING 6	卡簧 E6	1	-----
54		403S14005	SCREW M6X8	螺钉M6X8	1	-----
55		403S14005	SCREW	螺钉	1	-----
56		W02001	WASHER	弹簧垫圈	1	-----
57		w01009	WASHER	半垫	1	-----
58		42327004	SPRING	压簧	1	-----

9. SENSOR COMPONENTS
安全开关部件

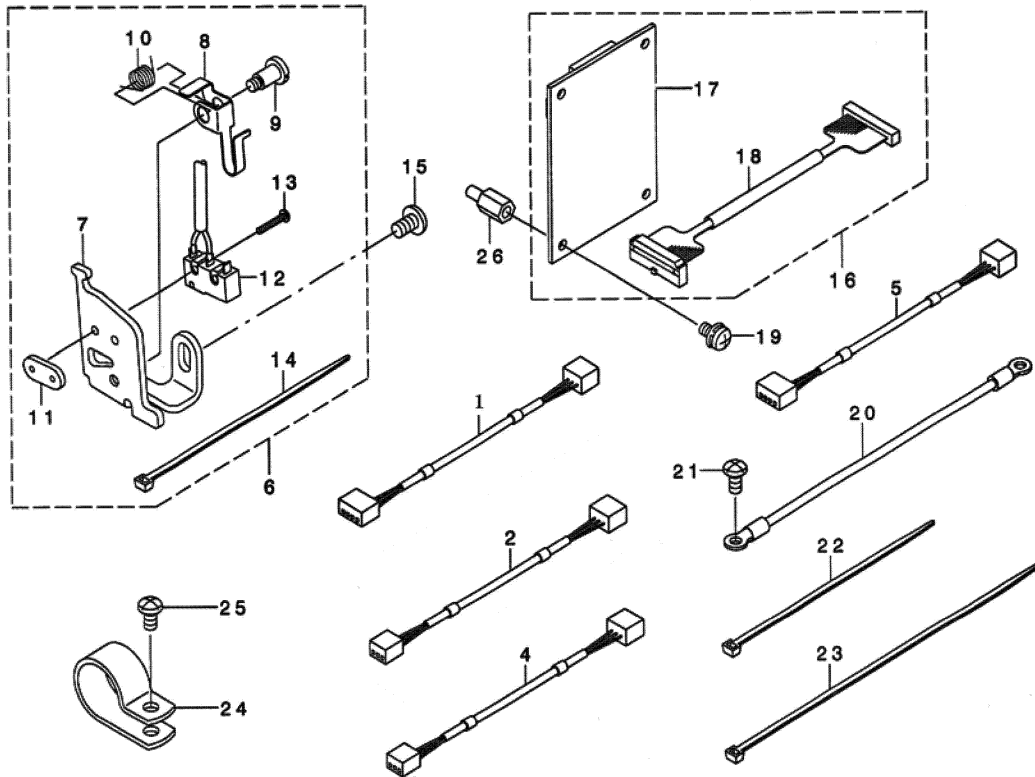

序号	注释	公司件号	DESCRIPTION	名称	用量	同类编码
1		40330036	AT SENSOR CABLE ASM	拾压传感器电缆	1	400-05729
2		40330037	Y SENSOR CABLE ASM	Y向传感器电缆	1	400-05731
4		40330038	X SENSOR CABLE ASM	X向传感器电缆	1	400-05730
5		40330039	TT SENSOR CABLE ASM	剪线传感器电缆	1	400-05733
6		- - - - -	SAFETY SW ASM	安全开关组件	1	400-06495
7		40312131	SAFETY SW BASE	安全开关架	1	400-06496
8		40312132	SAFETY SWITCH ASM	安全开关臂	1	236-38109
9		403s20020	SAFETY SW ASM SHAFT	轴位螺钉	1	400-06497
10		40327024	SAFETY SWITCH SPRING	安全开关弹簧	1	236-38208
11		40312133	SAFETY SWITCH NUT	安全开关板	1	236-38406
12		4033003200	SAFETY SW CABLE ASM	安全开关感应器组件	1	400-05734
13		403s11050	SCREW M2 L=12	螺钉	2	SM-4021201-SC
14		40111005	CABLE BAND	扎带	1	EA-9500B01-00
15		403S11010	SCREW M5 L=8	螺钉	1	SM-4050855-SP
16		4033003300	INT PCB ASM	转接板组件	1	400-05664
17		40330034	INT PCB	转接板	1	400-05660
18		40330035	INT CABLE ASM	转接板电缆	1	400-05725
19		413s13008	SCREW M4 L=8	螺钉组件	4	SL-4040881-SF
20		40330040	HEAD GROUND CABLE A ASM	地线	1	141-15554
21		403s11027	SCREW M4 L=8	螺钉	1	SM-4040855-SP
22		40111005	CABLE BAND	扎带	6	EA-9500B01-00
23		40311023	CABLE BAND 150	扎带	3	EA-9500B02-00
24		40311024	CABLE CLIP	线夹	1	HX-0015000-0K
25		403s11027	SCREW M4 L=8	螺钉	1	SM-4040855-SP
26		413s30007	STUD	定位螺钉	4	HX-0033900-00

10. THREAD STAND COMPONENTS

线架部件

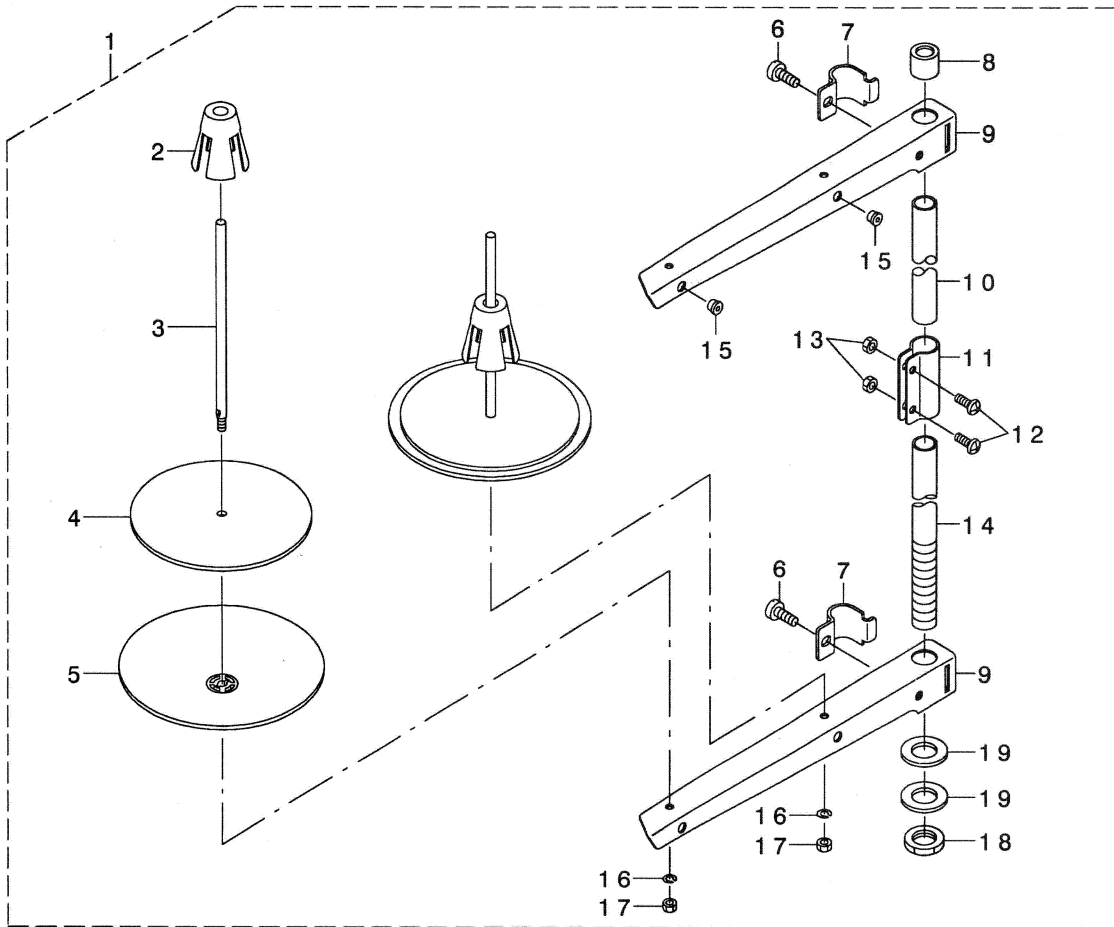

REF. NO	NOTE	PART NO.	名称	DESCRIPTION	Qty
1		1013100700	过线架组件	THREAD STAND ASM.	1
2		-----	线架缓冲支架	SPOOL RETAINER	(2)
3		-----	线轴	SPOOL PIN	(2)
4		-----	线盘软垫	SPOOL REST CUSHION	(2)
5		-----	线盘	SPOOL REST	(2)
6		-----	螺钉	SCREW M6 L=16	(2)
7		-----	过线架固定夹	THREAD GUIDE ARM JOINT	(2)
8		-----	线架支撑套	SPOOL REST ROD RUBBER CAP	(1)
9		-----	线架	SPOOL REST ARM	(2)
10		-----	线架支撑管 1	SPOOL REST ROD, UPPER	(1)
11		-----	支撑管接头	SPOOL REST ROD JOINT	(1)
12		-----	螺钉	SCREW M5 L=14	(2)
13		-----	螺母	NUT M5	(2)
14		-----	线架支撑管 2	SPOOL REST ROD, LOWER	(1)
15		-----	过线套	THREAD GUIDE	(2)
16		-----	弹簧垫圈	SPRING WASHER	(2)
17		-----	螺母	NUT M5	(2)
18		-----	螺母	NUT M16X1.5	(1)
19		-----	垫片	WASHER 17X30X2.6	(2)

11. TABLE STAND COMPONENTS (JT-K44)
台板机架部件

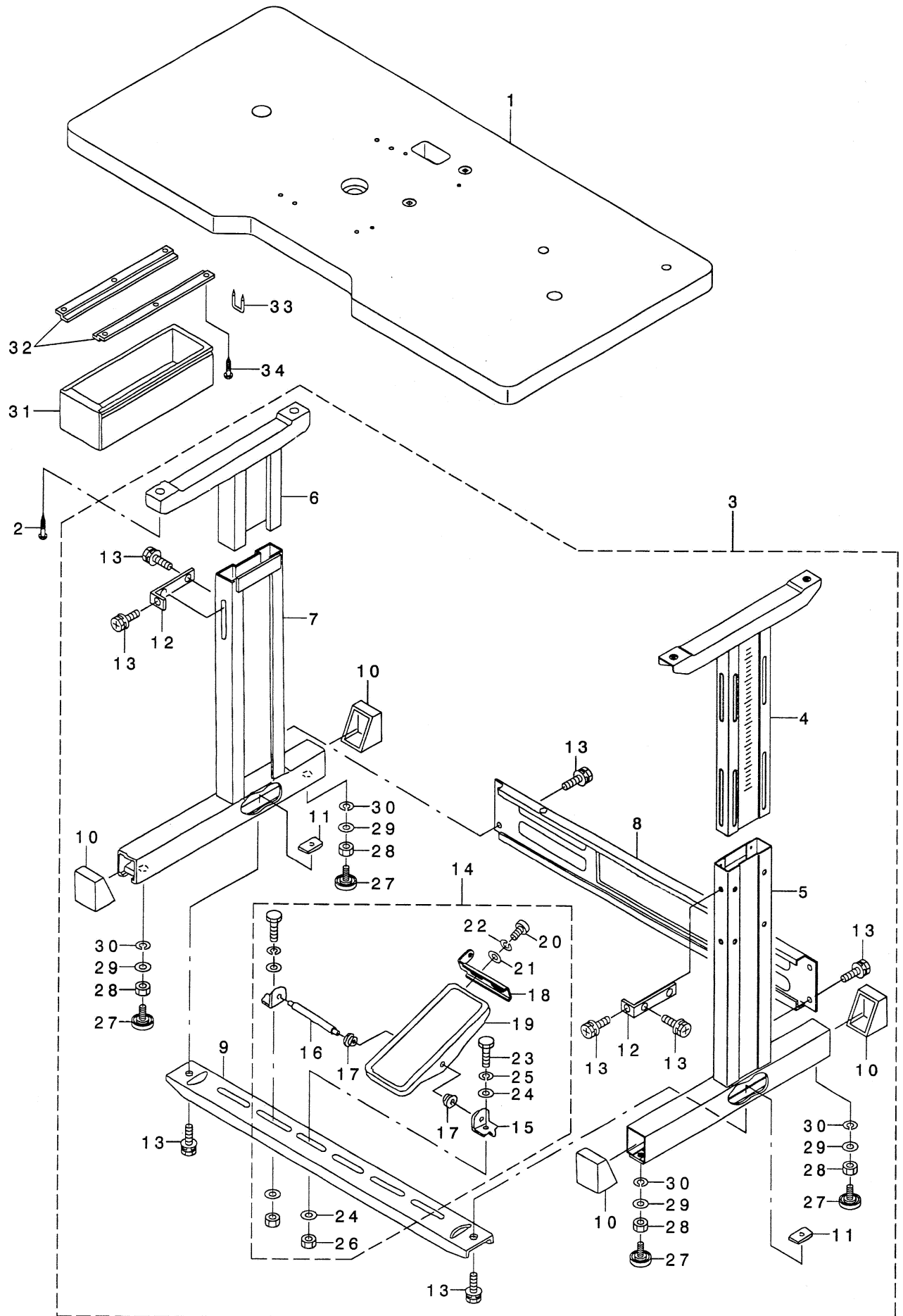

序号	注解	公司件号	DESCRIPTION	名称	用量	同类编号
1		40332002	TABLE	台板	1	400-06886
2		- - - - -	WOOD SCREW D=5.1 L=32	自攻螺丝	4	SK-3515201-SE
3		- - - - -	T-STAND COMPL	桌脚组件	1	141-18053
4		- - - - -	UPPER STAND ASM., RIGHT	右桌脚上支架	1	141-18152
5		- - - - -	STAND ASM., RIGHT	右桌脚下支架	(1)	141-18151
6		- - - - -	UPPER STAND ASM., LEFT	左桌脚上支架	(1)	B8101-210-AAB
7		- - - - -	STAND ASM., LEFT	左桌脚下支架	(1)	B8105-210-AAA
8		- - - - -	STAND SIDE SUPPORT	桌脚横撑	(1)	111-58300
9		- - - - -	STAND SIDE SUPPORT	桌脚横撑	(1)	111-58409
10		- - - - -	RUBBER CAP	橡胶套	(4)	111-58607
11		- - - - -	NUT	螺母	(2)	170-07402
12		- - - - -	UPPER STAND PLATE	调节压板	(2)	111-58516
13		- - - - -	WASHER HEXAGONAL BOLT	螺钉	(12)	SL-9082091-SE
14		- - - - -	Z-STAND PEDAL ASM	踏板组件	(1)	138-17754
15		- - - - -	PEDAL SHAFT BRACKET	踏板支架	(2)	111-59001
16		- - - - -	PEDAL CONNECTING ROD	踏板连接轴	(1)	B8153-771-000
17		- - - - -	PEDAL BUSHING	踏板轴衬	(2)	D8113-555-B00
18		- - - - -	PEDAL ADJUSTING PLATE	踏板调节板	(1)	GPF-06080000
19		- - - - -	PEDAL ASM.	踏板	(1)	GPF-060600A0
20		- - - - -	SCREW M6 L=12	螺钉M6×12	(2)	SM-9061203-SE
21		- - - - -	WASHER 6.7×13×1	垫片	(2)	WP-0671016-SE
22		- - - - -	SPRING WASHER 6.2×11.4×1.2	弹簧垫片	(2)	WS-0621210-KR
23		- - - - -	SCREW M8 L=20	螺钉M8×20	(2)	SM-9082023-SE
24		- - - - -	WASHER 8.7×18×1.6	垫片	(4)	WP-0871602-SE
25		- - - - -	SPRING WASHER 8.6×15×1.4	弹簧垫片	(2)	WS-0861410-KR
26		- - - - -	NUT M8	螺母	(2)	NM-6080721-SE
27		- - - - -	ADJUSTING SCREW ASM. WITH CAP	带垫调节螺钉	(4)	B8108-555-0A0
28		- - - - -	NUT M12	螺母M12	(4)	NM-6120001-SE
29		- - - - -	WASHER M12	垫片	(4)	WP-1302501-SE
30		- - - - -	SPRING WASHER 12.5×21.5×3	弹簧垫片	(4)	WS-1253010-KN
31		- - - - -	DRAWER	抽屉	1	111-55108
32		- - - - -	DRAWER SUPPORT	抽屉支架	2	111-55207
33		- - - - -	DRAWER STOPPER	抽屉挡板	1	D8204-555-D00
34		- - - - -	WOOD SCREW D=3.1 L=16	木螺钉	6	SK-3311601-SE

12. CONTROL BOX COMPONENTS

控制箱关系

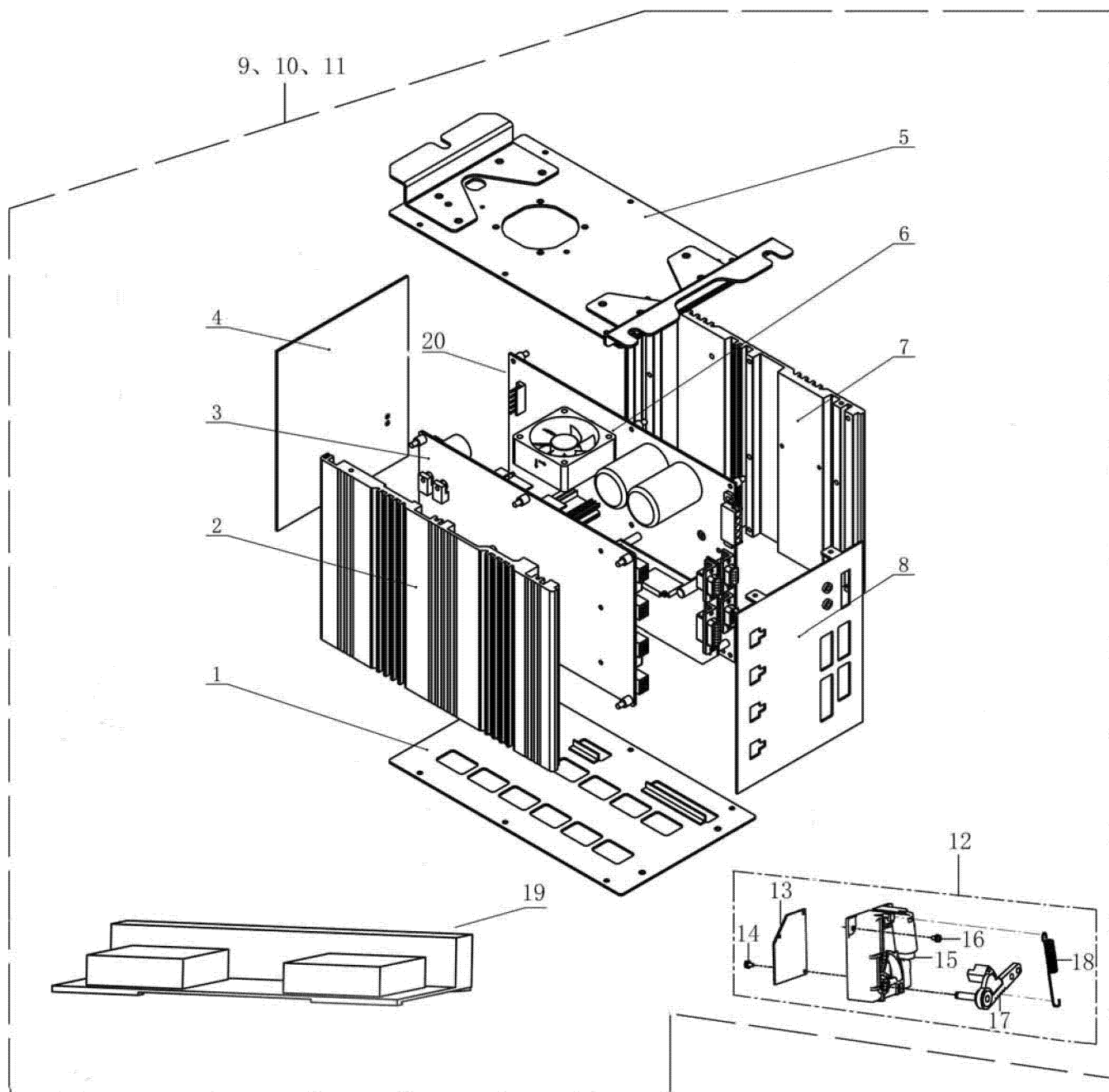

序号	注释	公司件号	DESCRIPTION	名称	用量	同类编号
1		- - - -	CONTROL BOX BASE COVER.	底板	1	- - - -
2		- - - -	CONTROL BOX FRONT COVER.	前盖板	1	- - - -
3		40330041	STEP DRIVER	步进板	1	- - - -
4		- - - -	CONTROL BOX LEFT COVER.	左盖板	1	- - - -
5		- - - -	CONTROL BOX FITTING PLATE	电控箱安装板	1	- - - -
6		40330043	FAN MOTOR ASS'Y	风扇	1	- - - -
7		- - - -	CONTROL BOX BACK COVER.	后盖板	1	- - - -
8		- - - -	CONTROL BOX RIGHT COVER.	右盖板	1	- - - -
9		4033104400	CONTROL BOX ASM.	电控箱组件(按键)	1	- - - -
10		4033104500	CONTROL BOX ASM.	电控箱组件(液晶)	1	- - - -
11		4233100400	CONTROL BOX ASM.	电控箱组件(双踏)	1	- - - -
12		4033003000	PEDAL SENSOR ASM	踏板传感器组件(单踏)	1	- - - -
13		- - - -	PEDAL INTERFACE BOARD	踏板接口板	1	- - - -
14		- - - -	SCREW	螺钉	3	- - - -
15		- - - -	PEDAL SENSOR BASE	踏板传感器底座	1	- - - -
16		- - - -	SCREW	螺钉	3	- - - -
17		- - - -	PEDAL LEVER	踏杆	1	- - - -
18		- - - -	SPRING	弹簧	1	- - - -
19		4033003100	PEDAL SENSOR ASM	踏板传感器组件(双踏)	1	- - - -
20		40330042	SYSTEM BOARD	主控板	1	- - - -

13、OPERATION PANEL COMPONENTS

操作屏部件

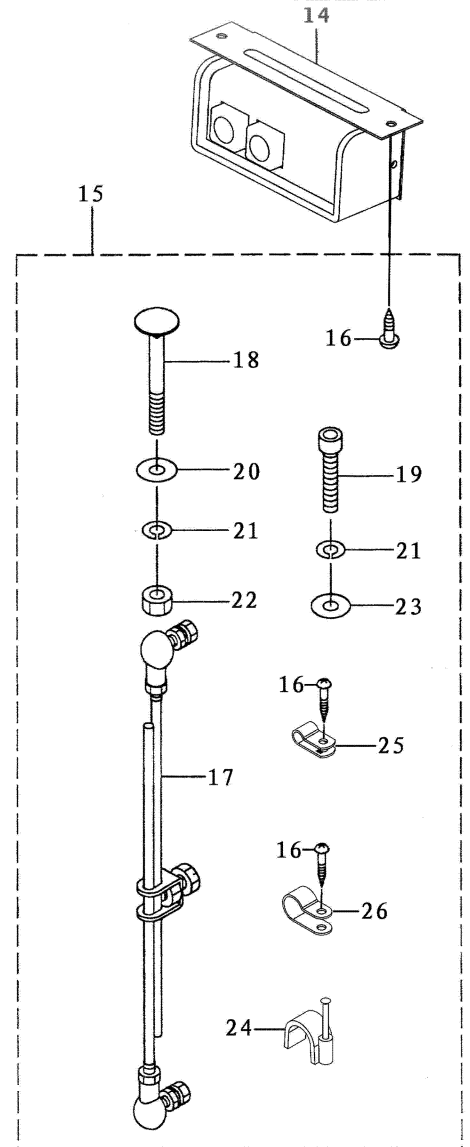
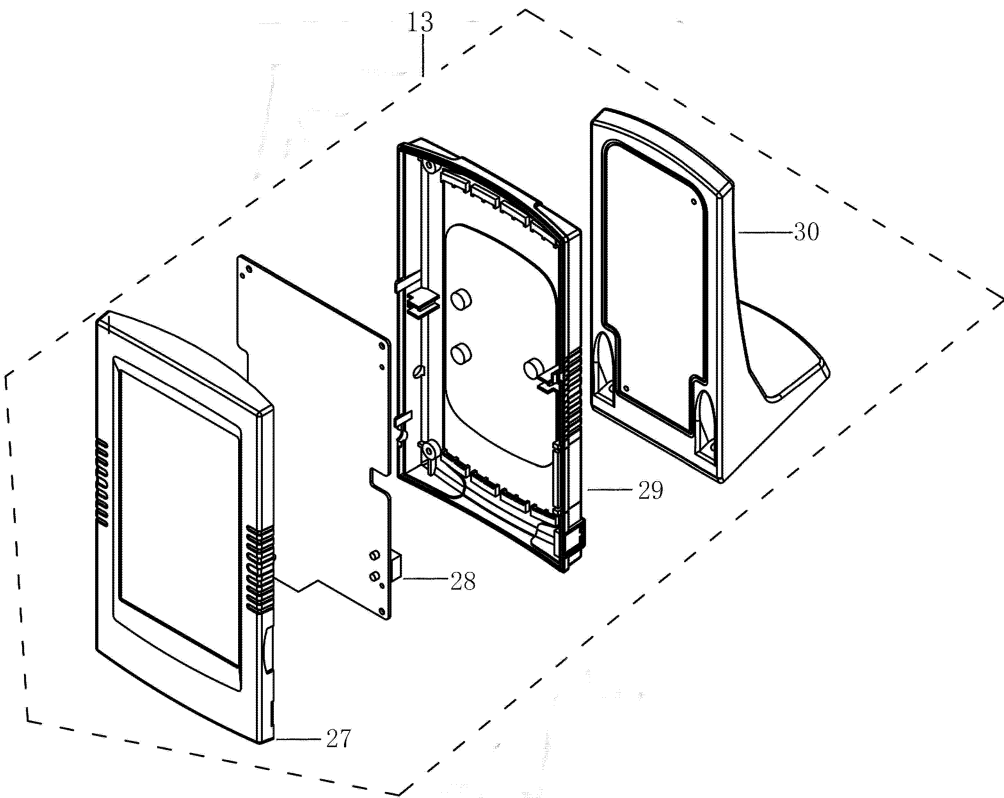
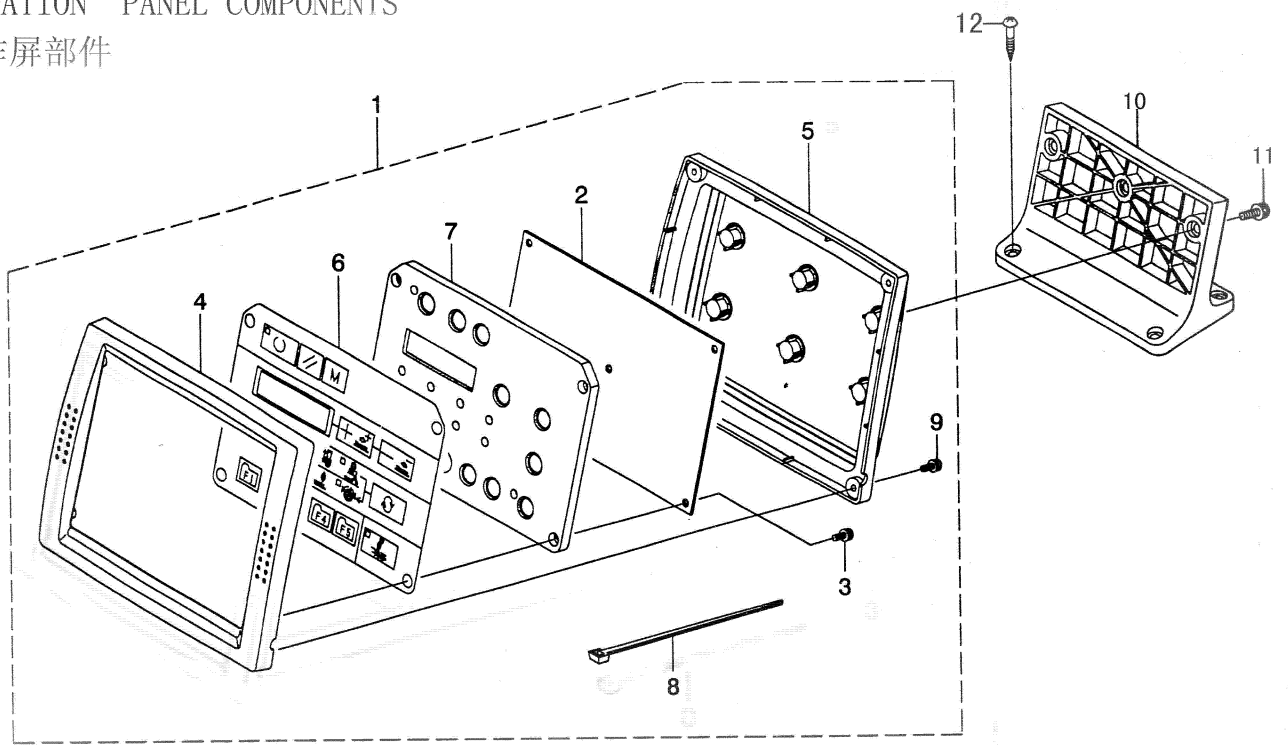

序号	注解	公司件号	DESCRIPTION	名称	用量	同类编号
1		4033002800	OPERATION BOX A ASM.	操作面板组件(按键)	1	-----
2		-----	PANEL PCB ASS'Y	面板电路板	1	-----
3		-----	SCREW M3X11	螺钉 M3X10	1	SL-4031081-SC
4		-----	OPERATION BOX FRONT CASE	操作面板前盖	1	-----
5		-----	OPERATION BOX REAR CASE	操作面板后盖	1	-----
6		-----	OPERATION PANEL SHEET	操作面板膜	1	-----
7		-----	PANEL PCB HOLDER PLATE	操作面板按键	1	-----
8		-----	CABLE BAND	扎带	1	EA-9500B01-00
9		-----	SCREW M3X10	螺钉 M3X10	1	SL-4031081-SC
10		-----	OPERATION BOX FITTING PLATE	操作面板固定底座	1	-----
11		-----	SCREW M4X16	螺钉 M4X16	1	SL-4041691-SC
12		-----	WOOD SCREW D=3.8 L=12	木螺钉	1	SK-3382001-SE
13		4033002900	OPERATION BOX A ASM.	操作面板组件(液晶)	1	-----
14		40330030	SWITCH	电源开关	1	-----
15		-----	ACCESSORIE PARTS A ASM.	连杆组件	1	-----
16		s05035	WOOD SCREW	木螺钉	7	-----
17		4133102000	CONNECTING ROD ASM	脚踏连杆	1	-----
18		401S30019	BOLT	螺栓	2	-----
19		403S13020	SCREW	螺钉	1	-----
20		W01018	WASHER	垫片 M8	2	-----
21		40128029	SPRING WASHER , M8	弹簧垫圈8. 2X15. 4X2	3	-----
22		401S16018	NUT M8	螺母 M8	2	-----
23		W01018	WASHER, 8. 4X17. 4X1. 6	垫片 8. 4X17. 4X1. 6	1	-----
24		40311014	CORD STAPLE	线卡	2	-----
25		40511001	CABLE CLAMP	线夹	3	-----
26		40311016	CABLE CLAMP	线夹	2	-----
27		-----	OPERATION BOX FRONT CASE	操作面板前盖	1	-----
28		-----	PANEL PCB ASS'Y	面板电路板	1	-----
29		-----	OPERATION BOX REAR CASE	操作面板后盖	1	-----
30		-----	OPERATION BOX FITTING PLATE	操作面板固定底座	1	-----

14、WIRING DLGRAM

电线装配图

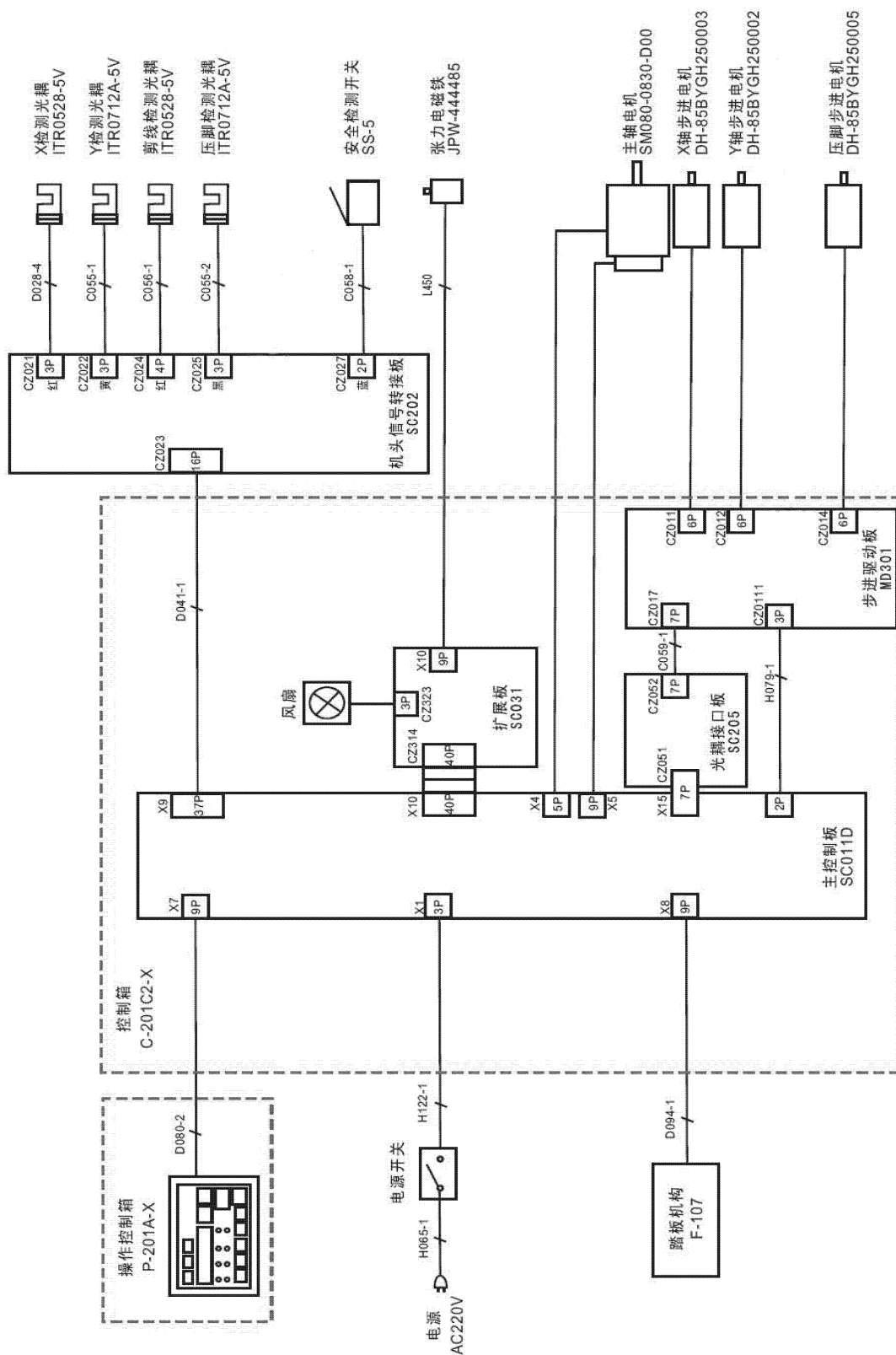

15. ACCESSORIE PART COMPONENTS

附件部件

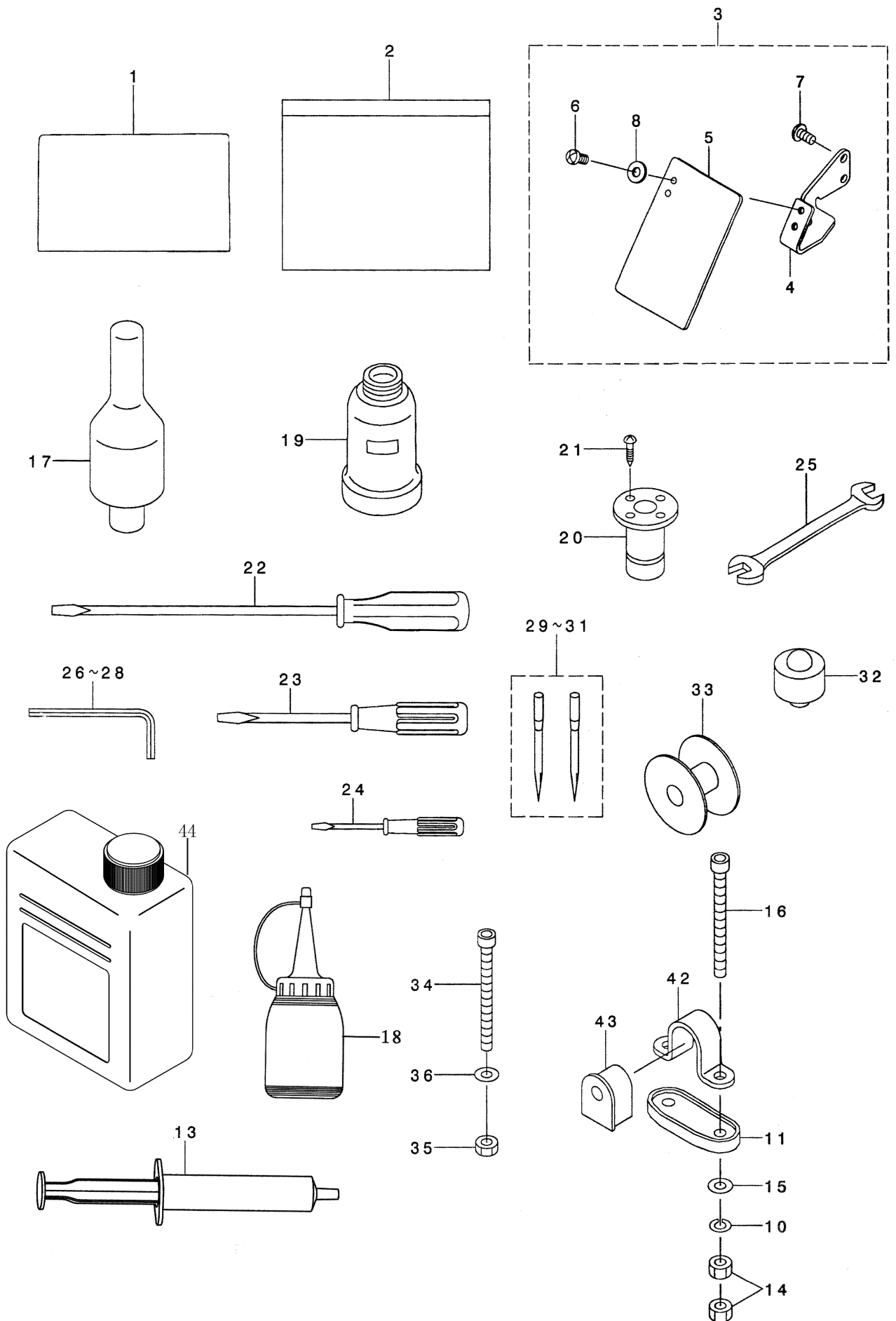

序号	注解	公司件号	DESCRIPTION	名称	用量	同类编号
1		40131017	HEAD-COVER	机头罩	1	B9118-232-000
2	- - - - -		ACCESSORIE BAG	附件袋	1	229-32800
3	- - - - -		SAFETY PLATE ASM	防护罩组件	1	400-06484
4		40312127	SAFETY PLATE BASE	防护罩安装板	(1)	400-51987
5		40911006	SAFETY PLATE	防护罩	(1)	B3120-372-000
6		403s11051	SCREW M4 L=6	螺钉	(2)	SM-4040655-SP
7		403s11027	SCREW	螺钉	(1)	SM-4040855-SP
8		40928002	WASHER 4.5X10X0.8	垫圈	(2)	WP-0450801-SD
10		40328039	SPRING WASHER 6.1X12.2X1.5	弹簧垫片	4	WS-0610002-KN
11		40322032	BED-HINGE-RUBBER	铰接板橡皮垫	2	400-16195
13		11411029	GREASE-B-TUBE	润滑脂	1	400-13640
14		N01007	NUT M6	螺母	8	NM-6060001-SC
15		40128013	WASHER	垫片	4	WP-0651646-SC
16		403S10010	BOLT M6 L=60	螺栓	4	SM-6066002-TN
17		40311002	HEAD SUPPORT BAR	机头支撑柱	1	141-01208
18		20131038	OILER (CONTAINING)	油壶	1	B9121-220-0A0
19		40311011	OIL CAN	回油油壶	1	B9121-012-000
20		40311010	OIL MANAGEMENT	油壶接头	1	B8202-205-000
21		S01003	WOOD SCREW D=3.1 L=16	木螺钉	4	SK-3311601-SE
22		10131002	SCREW DRIVER, LARGE	大螺丝刀	1	229-33006
23		10131003	SCREW DRIVER, MIDDLE	中螺丝刀	1	229-33105
24		10131004	SCREW DRIVER, SMALL	小螺丝刀	1	229-33204
25		40931025	WRENCH (9X10)	扳手	1	B9113-012-000
26		30131010	HEXAGONAL WRENCH, SMALL	小内六角扳手	1	B9140-372-000
27		20131047	HEXAGONAL WRENCH, LARGE	大内六角扳手	1	B9141-372-000
28		30131012	HEXAGONAL SRANNER	中内六角扳手	1	GCT-02906000
29		40117001	NEEDLE DPX5 # 16-2	机针DPx5 #16	4	MDP-500B1402
30	- - - - -		NEEDLE DPX17 # 21-2	机针DPx17 #21	4	MDP-170B2102
31	- - - - -		NEEDLE DPX5 # 11-2	机针DPx5 #11	4	MDP-500B1102
32		40322033	FRAME-SUPPORT-RUBBER	橡皮垫	2	400-16194
33		40118004	BOBBIN	梭心	3	138-12102
34		403S10010	BOLT M6 L=60	螺栓	1	SM-6066002-TN
35		N01007	NUT M6	螺母	1	NM-6060001-SC
36		40128013	WASHER	垫片	1	WP-0651646-SC
42		40312001	BED HINGE	铰接板	2	B1111-210-D00
43		40322003	HINGE RUBBER	铰接板橡胶座	2	B1115-210-D00
44		20131037	OILER (CONTAINING)	油壶	1	- - - - -

20. EXCLUSIVE PARTS FOR JK-T1903B(1)

1903B专用部件1

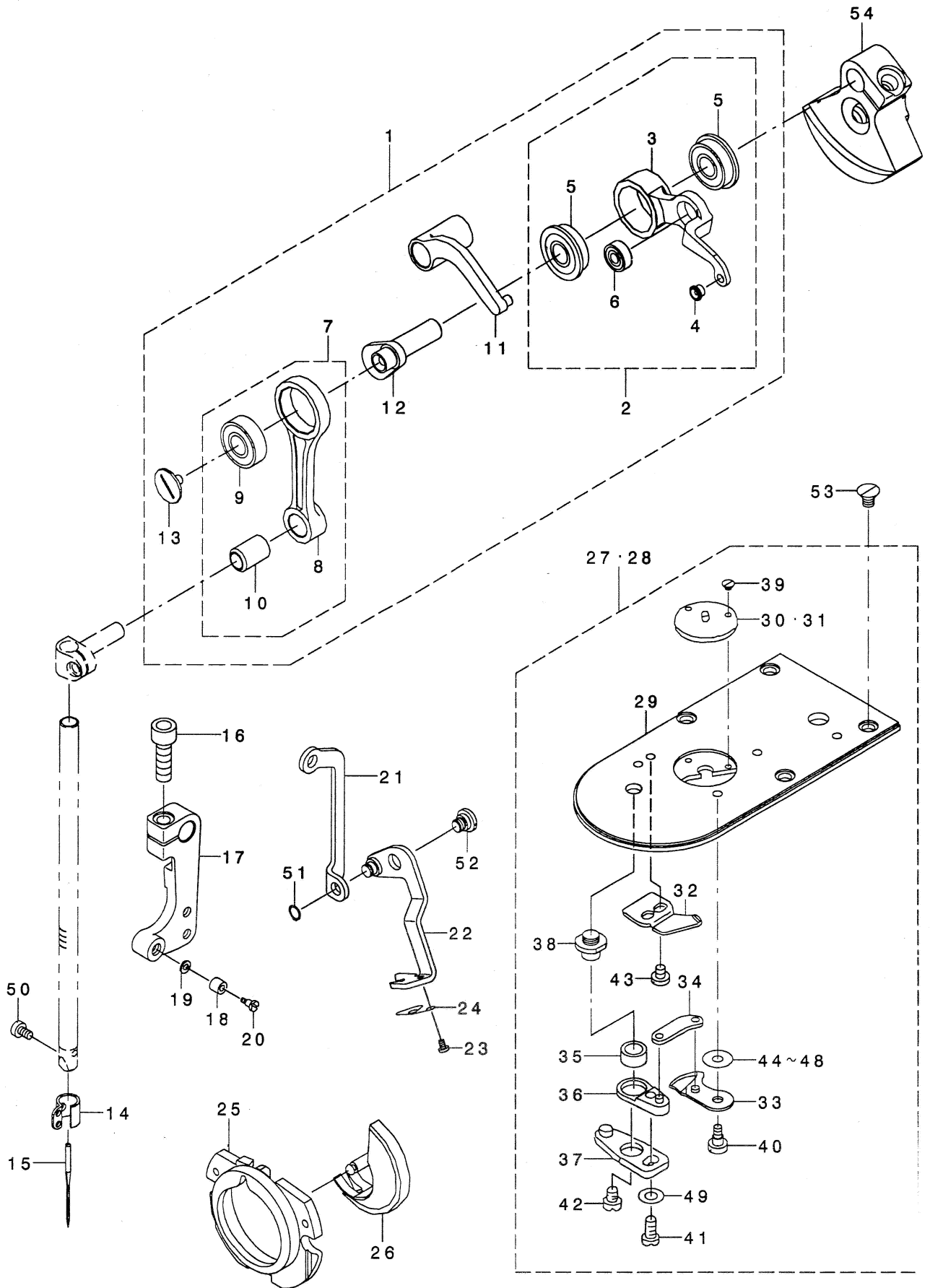

序号	注解	公司件号	DESCRIPTION	名称	用量	同类编号
1		4053800200	THREAD TAKE UP B COMPL.	挑线连杆组件	1	400-06923
2			THREAD TAKE UP LEVER B ASM.	挑线杆组件	(1)	400-06924
3		40338003	THREAD TAKE UP LEVER	挑线杆	(1)	400-06925
4		40313008	THREAD PASS BUSH	过线管	(1)	B1908-505-000
5		40324005	BEARING	轴承	(2)	SB-1080022-00
6		40324006	BEARING	轴承	(1)	SB-1040016-00
7			NEEDLE BAR CRANK ROD ASM.	针杆连杆组件	(1)	400-06534
8		40305011	NEEDLE BAR CRANK ROD	针杆连杆	(1)	400-06535
9		40324007	BEARING	连杆轴承	(1)	SB-1080023-00
10		40303014	NEEDLE BAR CRANK ROD METAL	连杆套	(1)	228-91006
11		40305012	THREAD TAKE UP CRANK	驼背连杆	(1)	400-06532
12		40504004	NEEDLE ROD CRANK	挑线曲柄	(1)	400-06926
13		403S30011	LEFT SCREW	螺钉	(1)	B1903-552-000
14		40313009	THREAD GUIDE	下过线	1	400-06525
15		40517001	NEEDLE DPX17 #14	机针DPx17#14	1	MDP-170B1400
16		S05030	SCREW	螺钉	1	SM-6061802-TP
17		40504005	CONNECTING ARM	曲柄	1	400-11949
18		40503001	STOP MOTION TRIPPING LEVER OAM	滚筒	1	B2619-372-000
19		40528001	HOOK SHAFT WASHER	垫片	1	B1853-512-00E
20		405S20001	HINGE SCREW D=7.94 H=12.7	铰链螺钉	1	SD-0791271-SP
21		40512014	WIPER-CONNECTING-PLATE	扫线连接拉板	1	400-06937
22		4051201500	WIPER ASM	扫线杆组件	1	400-33047
23		405S11007	SCREW3/32-56 L=2.8	螺丝3/32-56 L=2.8	2	SS-5060310-SP
24		40527014	WIPER THREAD CATCH SPRING	钩线弹簧	1	400-09860
25		40318004	INNER HOOK PRESSER ASM., C	梭床盖	1	141-03352
26		40118501	SHUTTLE	梭托	1	400-06580
27		4051500300	NEEDLE PLATE ASM., M	针板组件	1	400-06725
28			NEEDLE PLATE ASM., K	针板组件	1	400-06726
29		40315013	NEEDLE PLATE	针板	(1)	400-06721
30		40515001	GUIDE	小针板	(1)	MAZ-15801000
31			GUIDE	小针板	(1)	MAZ-15601000
32		40119002	FIXING KNIFE	固定刀片	(1)	B2424-280-000
33		40119001	MOVING KNIFE ASM.	转刀	(1)	B2421-280-0A0
34		40105003	MOVING KNIFE LINK	转刀连接杆	(1)	B2418-280-000
35		40103009	THREAD CUTTER LEVER RING	转刀连接环	(1)	B2416-280-000
36		4011202000	THREAD CUTTER LEVER ASM. ,SM	转刀驱动杆组件	(1)	B2415-280-0A0
37		4011202200	THREAD CUTTER LEVER ASM. ,LA	转刀驱动架组件	(1)	B2414-280-0A0
38		403S30004	THREAD CUTTER LEVER SHAFT	切线摇杆螺柱	(1)	B2417-280-000
39		401S17006	SCREW 3/32-56 L=2.2	开槽沉头螺钉	(2)	SS-1060210-TP
40		401S20007	HINGE SCREW D=5 H=0.9	合叶螺丝D=5.0 H=0.9	(1)	SD-0500091-TP
41		401S11021	SCREW 11/64-40 L=7	螺钉11" /64-40、L=7	(1)	SS-7110740-TP
42		401S20008	SCREW 11/64-40 L=4.0	螺钉11" /64-40、	(1)	SS-6110430-TP
43		401S11020	SCREW 9/64-40 L=3.5	螺钉	(2)	SS-7090410-SP
44		40128009	MOVING KNIFE WASHER A	转刀垫圈	(1)	B2423-280-00A
45			MOVING KNIFE WASHERB	转刀垫圈	(1)	B2423-280-00B
46			MOVING KNIFE WASHER C	转刀垫圈	(1)	B2423-280-00C
47			MOVING KNIFE WASHER D	转刀垫圈	(1)	B2423-280-00D
48			MOVING KNIFE WASHER E	转刀垫圈	(1)	B2423-280-00E
49		40128008	WASHER	垫圈	(1)	WP-0450846-SP
50		301S11014	SCREW	支针螺钉	1	SM-6030500-SN
51		40108011	RETAINING RING 4.7	卡簧	1	RC-0470611-KP
52		403s20016	HINGE SCREW D=6.35 H=2.1	螺钉	1	SD-0640216-TP
53		403S17002	SCREW M4 L=6	针板螺钉	4	SM-1040650-TP
54		40510001	COUNTER-WEIGHT-B	针杆曲柄	1	400-10429

21. EXCLUSIVE PARTS FOR JK-T1903B(2)

1903B专用部件2

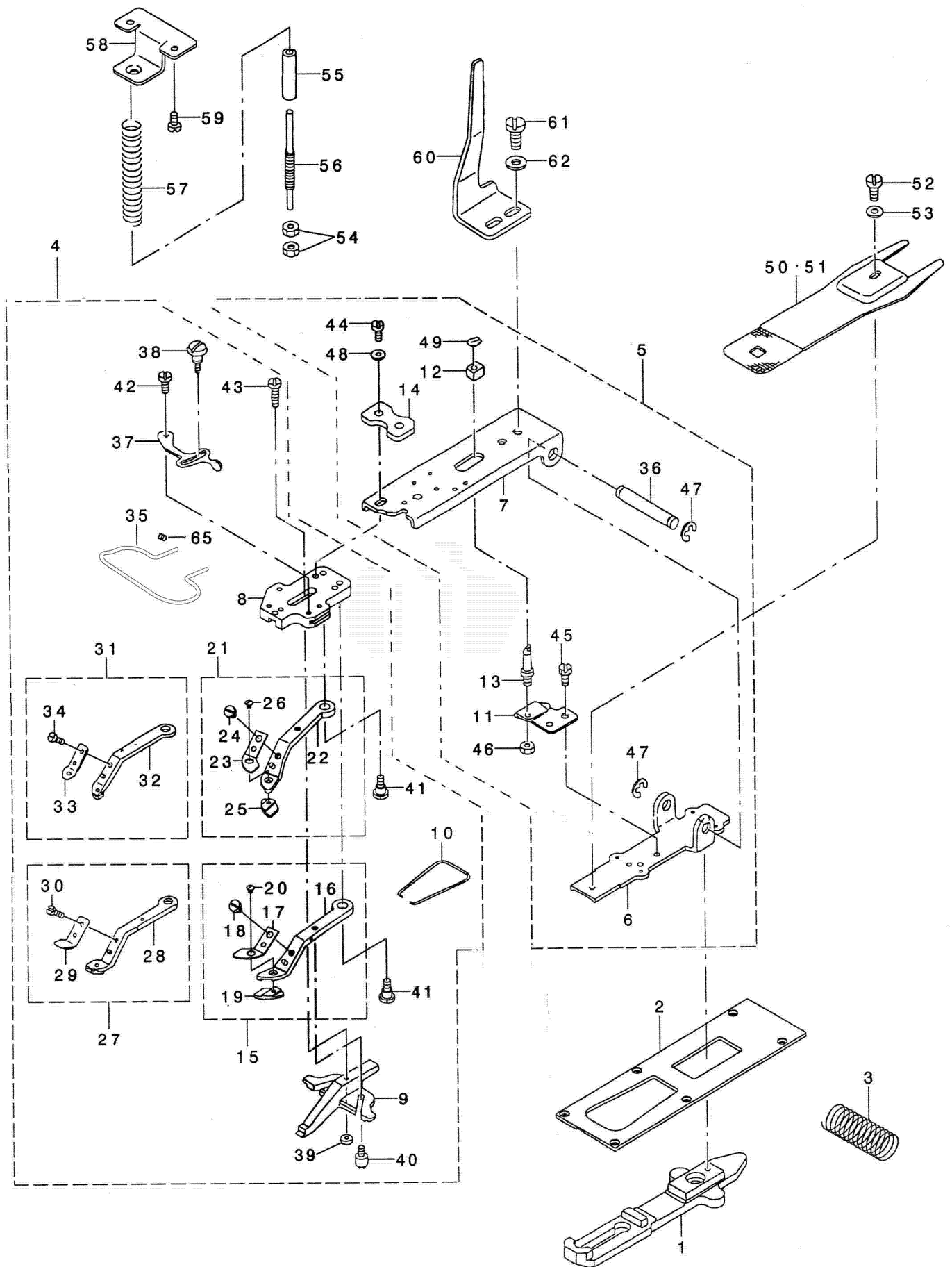

序号	注释	公司件号	DESCRIPTION	名称	用量	同类编号
1		40504002	CLOTH FEED PLATE	供给金属板组件	1	141-45106
2		40512017	CROTH FEED PRESSER PLATE B	供给压板	1	400-06935
3		40527015	VERTICAL FEED SHAFT SPRING	弹簧	1	141-48407
4		40521601200	VERY SMALL CLAMP MECHANISM ASM.	抓脚组件	1	141-45858
5		4032800300	MEDIUM CLAMP MECHANISM ASM.	抓脚提升板组件	1	141-45650
6		40512005	PICK-UP INSTALING BASE	爪脚提升板B	1	141-46104
7		40512004	PICK-UP FOOTINSTALING BASE	爪脚提升板A	1	141-46203
8		40509003	PICK-UP FOOTINSTALING BASE	安装板	1	141-46302
9		40501004	BUTTON CLAMP SLIDE	调节板	1	B2552-372-000
10		40527010	BUTTON CLAMP JAW LEVER SPRING	弹簧	1	MAZ-15513000
11		40512006	SUPPORT PLATE	安装板	1	MAZ-15514000
12		40509002	SLIDE BLOCK	滑块	1	MAZ-15515000
13		405S30001	STATIONING BLOCK SHAFT	螺栓	1	135-40901
14		40512010	PRESSER PLATE	安装板	1	141-46401
15		- - - - -	MIDDLE CLAMP JAW LEVER ASM. , R	右抓脚臂组件	1	141-49058
16		40516001	MIDDLE CLAMP JAW LEVER , R	右爪脚臂	1	MAZ-15507000
17		40527002	SPRING, RIGHT	压簧板	1	MAZ-15509000
18		405S11003	SCREW 9/64-40 L=3. 5	螺钉	1	SS-7090410-SP
19		40516002	PLATE L, R	右压料板	1	141-49009
20		201S17001	SCREW 3/32-56 L=3	螺钉	1	SS-2060310-SP
21		- - - - -	MIDDLE CLAMP JAW LEVER ASM. , L	左抓脚臂组件	1	141-49157
22		40516003	MIDDLE CLAMP JAW LEVER , L	左爪脚臂	1	MAZ-15508000
23		40527003	SPRING, LEFT	压簧板	1	MAZ-15510000
24		405S11003	SCREW 9/64-40 L=3. 5	螺钉	1	SS-7090410-SP
25		40516004	PLATE L, L	左压料板	1	141-49108
26		201S17001	SCREW 3/32-56 L=3	螺钉	1	SS-2060310-SP
27		- - - - -	EXTRA SMALL CLAMP LEVER ASM. , R	右抓脚臂组件	1	MAZ-158070BB
28		- - - - -	EXTRA SMALL CLAMP LEVER ASM. , R	右爪脚臂	1	MAZ-158070AB
29		- - - - -	SPRING, RIGHT	压簧板	1	MAZ-15809000
30		- - - - -	SCREW 9/64-40 L=3. 5	螺钉	1	SS-7090410-SP
31		- - - - -	EXTRA SMALL CLAMP LEVER ASM. , L	左抓脚臂组件	1	MAZ-158080BB
32		- - - - -	EXTRA SMALL CLAMP LEVER ASM. , L	左爪脚臂	1	MAZ-158080AB
33		- - - - -	SPRING, LEFT	压簧板	1	MAZ-15810000
34		- - - - -	SCREW 9/64-40 L=3. 5	螺钉	1	SS-7090410-SP
35		40527016	FINGER GUARD	护手	1	D3130-MIY-C00
36		40526001	INSTALLING SHAFT	连接销	1	141-41402
37		40912003	SNAP FASTENER CLAMP STOP LEVER	调节扳手	1	B2548-372-000
38		409S20003	CLAMP SCREW A	铰链螺钉A	1	B2549-372-000
39		405s20006	NUT	螺母	1	B2553-372-000
40		405s20007	BUTTON CLAMP STOP PIN	螺钉	2	B2560-372-000
41		405S20005	HINGE SCREW D=6. 35 H=3. 9	螺钉	2	SD-0640391-TP
42		409S20002	HINGE SCREW D=5. 5 H=1. 8	螺钉	1	SD-0550181-SP
43		405S20004	HINGE SCREW D=5. 5 H=3	螺钉	1	SD-0550301-SP
44		409S12001	SCREW 3/16-32 L=13. 5	螺钉	2	SS-9621413-SP
45		405S12001	SCREW 11/64-40 L=4	螺钉	2	SS-9110460-CP
46		401S16002	NUT 15/64-28	螺母	1	NS-6150310-SP
47		H03006	E-RING 7	卡簧	2	RE-0700000-K0
48		W01013	WASHER 5X10. 5X1	垫片	2	WP-0501016-SD
49		H05007	SNAP RING, FOR CONNECTING ROD	卡簧	1	D2548-232-D00
50		40515004	PRESSURE PLATE	送料板	1	MAZ-15502000
51		40515005	PRESSURE PLATE	送料板	1	MAZ-15602000
52		405S12003	SCREW 11/64-40 L=5. 3	螺钉	1	SS-9110543-CP
53		W01013	WASHER 5X10. 5X1	垫片	1	WP-0501016-SD
54		405S16001	THREAD TENSION NUT	螺母	2	B3125-012-000
55		40503002	SLEEVE	轴套	1	D2527-232-D00
56		405S30004	ADJUSTING SHAFT	调节螺柱	1	141-46906
57		40527005	PRESSURE SPRING	弹簧	1	138-12003
58		40512007	ACCEPT PLATE, UPPER	安装板	1	138-11906
59		403S13011	SCREW	螺钉	2	SM-5040855-SN
60		40512008	MOVING PLATE	提升控制板	1	MAZ-15516000
61		405S12002	SCREW 15/64-28 L=11	螺钉	2	SS-9151120-CP
62		40128014	WASHER 6. 1X15. 2X2. 5	垫片	2	WP-0612516-SD
65		405s15001	SCREW 9/64-28 L=11	螺钉	2	-----

22. ACCESSORIES PARTS FOR 1903B

1903B附件部件

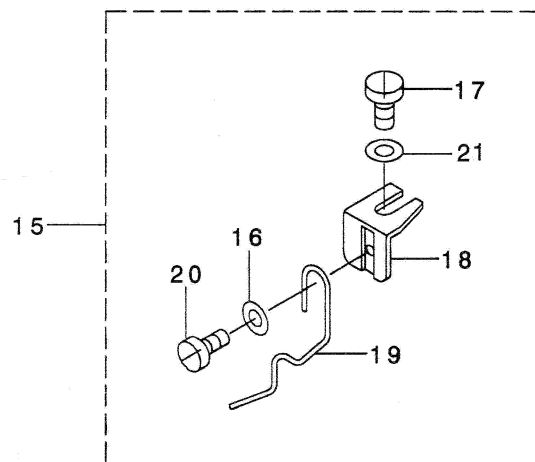
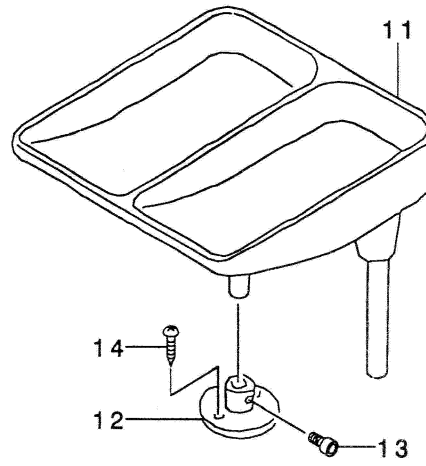
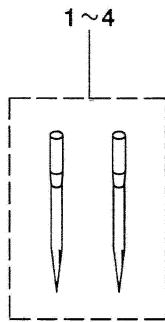

序号	注释	公司件号	DESCRIPTION	名称	用量	同类编号
1		- - - - -	NEEDLE DPX5#14-2	机针DPx5#14-2	4	MDP-500B1402
2		- - - - -	NEEDLE DPX5#16-2	机针DPx5#16-2	4	MDP-500B1602
3		- - - - -	NEEDLE DPX17#21-2	机针DPx17#21-2	4	MDP-170B2102
4		40517001	NEEDLE DPX17#14-2	机针DPx17#14-2	4	MDP-170B1402
11		4091100100	BUTTON TRAY ASM	纽扣盘	1	178-48458
12		300941	BUTTON TRAY BASE	纽扣盘固定座	1	400-33635
13		S10009	SCREW M6 L=12.	螺钉M6X12	1	SM-6061202-TP
14		S05035	WOOD SCREW D=4.1 L=12	木螺丝	2	SK-3412001-SE
15		- - - - -	BUTTON RISING BAR ASM	松线板组件	1	141-46757
16		40928021	WASHER 3. 7X8X0. 3	垫圈3. 7X8X0. 3	2	WP-0370316-SD
17		405S11006	SCREW 9/64-40 L=8	螺钉9/64-40 L=8	1	SS-9090813-TP
18		40512013	INSTALLING BASE	安装板	1	141-46807
19		40527013	BUTTON RISING BAR	纽扣松紧板	1	141-46708
20		301S11014	SCREW 1/8-44 L=2. 9	螺钉1/8-44	1	SS-6080340-SP
21		40128021	WASHER	垫圈	1	- - - - -

23. ACCESSORIES PARTS FOR 1904B AND 1906B

1904B和1906B专用部件2

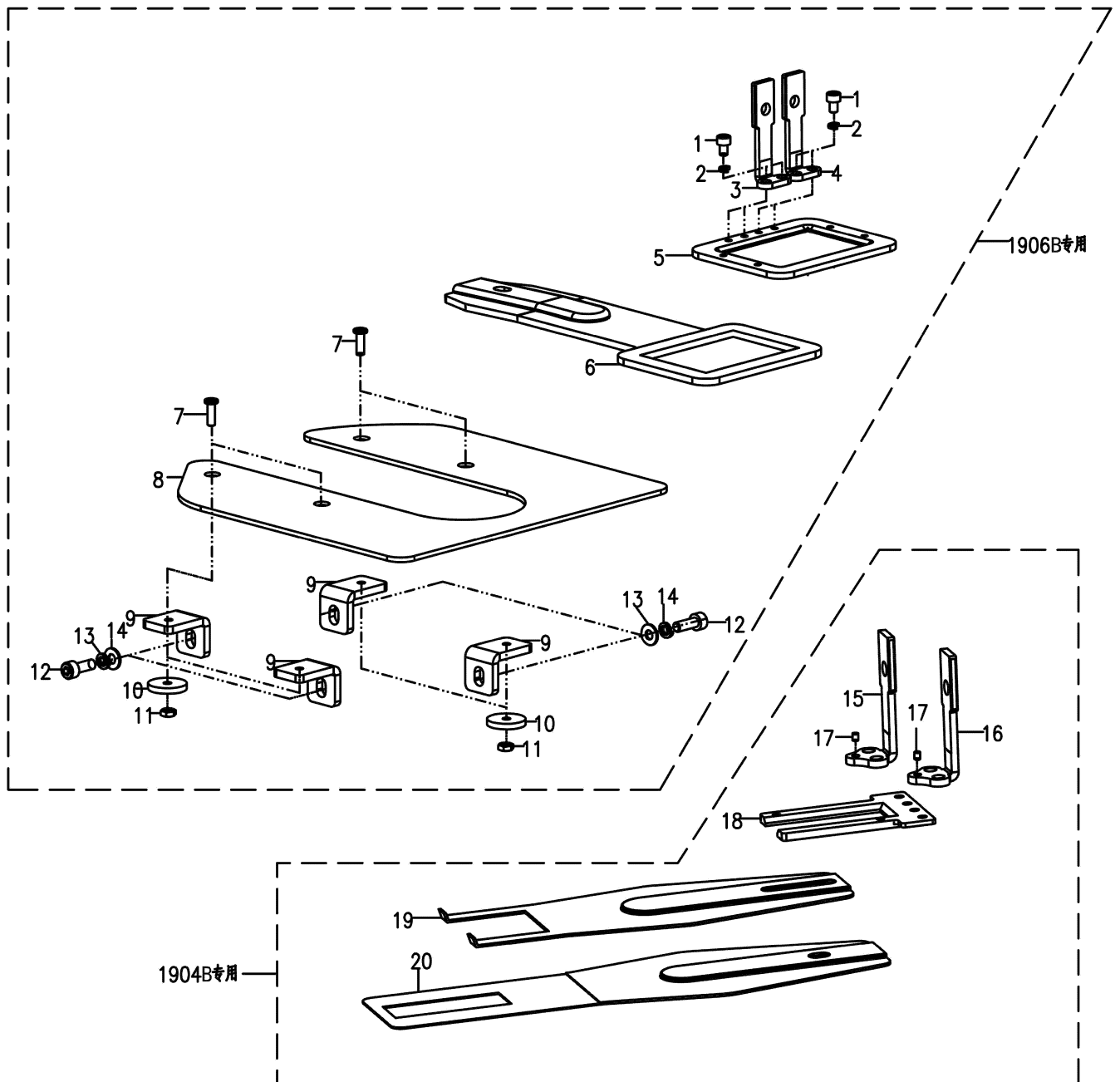

序号	注解	公司件号	DESCRIPTION	名称	用量	同类编号
1		403s13001	SCREWM4×6	螺钉M4×6	1	400-06711
2		W02002	WASHER SPRING	弹簧垫片	2	SM-8050592-TP
3		42316001	WORK CLAMP FOOT , LEFT	左压脚架	1	WP-0450801-SP
4		42316002	WORK CLAMP FOOT , RIGHT	右压脚架	1	HD-0022300-00
5		42316003	WORK CLAMP FOOT	压脚板	1	- - - -
6		42315002	FEED PLATE	送料板	1	400-40256
7		417s15003	SCREW M4×12	螺钉M4×12	1	400-06712
8		42312021	AUXILIARY PLATE AUXILIARY	辅助板	1	SD-0800327-TP
9		42312020	PLATE BRACKET AUXILIARY	辅助板支架	1	400-10525
10		41722010	PLATE CUSHION	补助板缓冲	1	NM-6050001-SP
11		N01015	CONNECTING BAR	螺母	1	400-06717
12		s05004	SCREW M5×15	螺钉M5×15	1	400-06716
13		W01013	WASHER	平垫片	1	SM-8060812-TP
14		W02001	WASHER SPRING	弹簧垫片	1	SM-6040802-TP
15		40316034	WORK CLAMP FOOT , LEFT	左压脚架	1	- - - -
16		40316033	WORK CLAMP FOOT , RIGHT	右压脚架	1	- - - -
17		409s14002	ADJUSTING SCREW	调节螺钉	1	- - - -
18		40316031	WORK CLAMP FOOT	压脚板	1	- - - -
19		40315022	FEED PLATE	送料压板	1	- - - -
20		40315023	FEED PLATE	送料板	1	- - - -